



MODEL 244/264/273/274/294 ELECTRON BEAM SOURCE

INSTRUCTION MANUAL

Copyright © TELEMARK, 1990-2019 – All rights reserved

January 2019

telemark.com

Brand and product names are trademarks or registered trademarks of their respective companies.

Current version of this manual can be found at
<https://telemark.com/electron-beam-sources/multi-pocket-sources/>

SAFETY WARNING

HIGH (POTENTIALLY LETHAL) VOLTAGES ARE PRESENT WITHIN EVAPORATION SYSTEM. GREAT CARE MUST BE EXERCISED WHEN PERFORMING MAINTENANCE.

HUMAN CONTACT WITH THE VOLTAGES CAN BE FATAL.

SHORT ALL HV FEEDTHRU CONNECTIONS WITH A GROUNDING HOOK.

DANGER – HIGH VOLTAGE

WARRANTY

This Electron Beam Source is guaranteed against faulty materials, function, and workmanship for a period of 12 months after delivery from Telemark.

This warranty is valid only for normal use where regular maintenance is performed as instructed. This warranty shall not apply if repair has been performed or an alteration made by anyone other than an authorized Telemark representative or if a malfunction occurs through abuse, misuse, negligence, or accident. No charge will be made for repairs made under warranty at Telemark's facilities. Defective parts will be repaired or replaced at Telemark's option. Customer will be responsible for freight charges to Telemark's facility.

For the safety of the Telemark technician's customers are requested to supply a list of materials which have been evaporated in the crucible when the electron beam source is returned for repair.

USER RESPONSIBILITY

The user is responsible for proper operation and ordinary maintenance of the equipment, following procedures described in this manual, including reference documents. Proper operation includes timely replacement of parts that are missing, broken, or plainly worn. If the user has a reasonable doubt about understanding the use or installation of a component, Telemark or your local representative should be called.

It is vitally important that the user properly install the equipment as described in Chapter 3 (Installation) of this manual, with particular attention to the correct grounding methods described.

The Warranty will be void if the equipment is improperly installed and/or properly grounded.

TABLE OF CONTENTS

1	<u>UNPACKING</u>	6
2	<u>DESCRIPTION</u>	7
3	<u>SPECIFICATIONS</u>	9
4	<u>INSTALLATION</u>	10
	<u>Required Components</u>	10
	<u>Setting Up</u>	11
	<u>Grounding</u>	12
	<u>High Voltage</u>	13
	<u>Ground Connections</u>	13
	<u>Two Source Installation</u>	14
5	<u>OPERATION</u>	16
	<u>General Operation – Startup</u>	16
	<u>General Operation – Shutdown</u>	17
	<u>Adjusting the Electromagnetic Field</u>	17
6	<u>SERVICING</u>	18
	<u>Crucible Removal</u>	18
	<u>Crucible Replacement</u>	19
	<u>Emitter Removal</u>	20
	<u>Emitter Disassembly and Cleaning</u>	20
	<u>Filament Replacement</u>	20
	<u>Emitter Rebuilding/Reassembly</u>	20
	<u>Source Disassembly</u>	22
	<u>Crucible Rotation Assembly</u>	23
	<u>Crucible Quick Check</u>	24
	<u>Coil Assembly</u>	25
	<u>Side Drive Assembly</u>	25
	<u>Bottom Drive Assembly</u>	25
	<u>Main Body Reassembly</u>	25
	<u>Quick Check</u>	27

7	<u>KITS AND ACCESSORIES</u>	<u>28</u>
	Installation Kits	28
	Accessories	29
	Replacement Crucibles	31
	Rebuild Kits	32
	Change Over Kit	34
8	<u>TROUBLESHOOTING</u>	<u>35</u>
	Power Problems	35
	Beam Problems	36
	Rotation Problems	37

1

UNPACKING

Your electron beam source is packed into a specially designed double strength box and surrounded with two and a half inches of rigid foam padding. Since packaging the source for safe shipment is otherwise difficult, please save the box in the event that the source ever needs to be returned for servicing. Telemark cannot be held liable for sources which are damaged in transit as a result of improper packaging.

Inside the box are the source and installation kit. The installation kit includes: a set of tools, a spare seal kit and an emitter rebuild kit. Please check the packaging list to make sure no damage has occurred in transit. Inspect the emitter assembly for alignment of the filament, anode plate and beam former. The source is ruggedly built and packaged tightly to prevent damage. In the event of any deficiencies, please report them to your vendor immediately. Also take care to read the warranty regarding the limits of Telemark's liabilities.

The finish on the metal parts of the source is the highest available. The source is assembled under clean conditions and sealed in a polyethylene bag for shipment. A set of white gloves is included for your use in unpacking and setting up the source to help minimize contamination.

2

DESCRIPTION

The electron beam source's most notable features:

Some models have crucibles that can be removed from above by simply removing the screws that hold them in place. This feature allows the crucible to be cleaned or replaced without removing the source from the vacuum chamber or disassembling the entire source. This process is described in the Servicing Manual.

The emitter assembly is a critical component in the operation of the electron beam source. The parts that make up the emitter assembly are manufactured to exacting standards. Telemark has developed several innovative changes to the emitter assembly which make it more reliable and easier to assemble.

The sweep coils are sealed in a water-cooled solid copper block or are sealed in a stainless steel can that is attached to a water-cooled solid copper block. This virtually eliminates the possibility of damaging the coils thermally or mechanically during normal production or handling. As long as proper water flow is maintained in the EB source and care is taken not to drop it, the coils should last indefinitely.

Other features, such as heavy-duty screws with Helicoil® inserts in the copper in all important fastening locations, reliable vacuum connections, and heavy-duty construction in general, are designed to make the source serviceable for years of production.

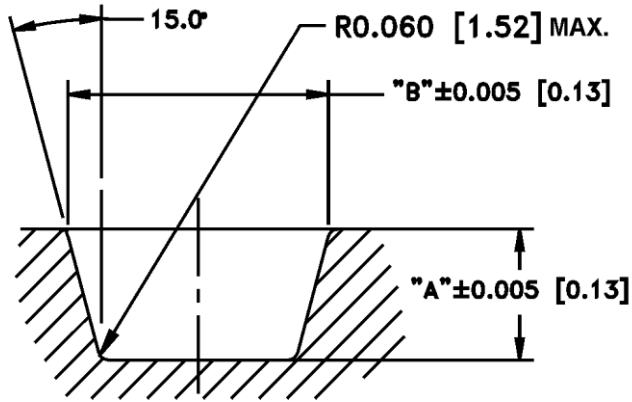

Standard Crucible

Figure 2-A Crucible Dimensions

Size	"A"		"B"	
	Inch	mm	Inch	Mm
4cc	.575	14.61	.885	22.48
7cc	.500	12.70	1.125	28.58
15cc	.670	17.02	1.485	37.72
25cc (Shallow)	.680	17.27	1.855	47.12
25cc (Deep)	.920	23.37	1.633	41.48
30cc (with Web)	.790	20.07	1.920	48.77
30cc (W/O web)	.940	23.88	1.800	45.72
40cc	1.020	25.91	2.030	51.56

3

SPECIFICATIONS

Specifications	244 EB Source	264/273/274 EB Source	294 EB Source
Electron Beam Deflection	270°	270°	270°
Power Rating	6 kW	10 kW	10 kW
High Voltage Range	-6 kV to -10 kV	-6 kV to -10 kV	-6 kV to -10 kV
Lateral Coil Resistance	7.5 ohms	3.0 ohms	3.0 ohms
Longitudinal Coil Resistance	9.5 ohms	9.6 ohms	9.6 ohms
Emission Current	0 to 500 mA @ 10kV	Up to 1 amp @ 10kV (264/266/274/276) Up to 1 amp @7 kV (273, dielectric only)	Up to 1 amp @ 10kV
Filament Power	600 watts maximum (50 Amps at 12 VAC max).	600 watts maximum (50 Amps at 12 VAC max).	600 watts maximum (50 Amps at 12 VAC max).
Sweep Lateral Coil	+/-1.5 amps	+/-1.5 amps	+/-1.5 amps
Sweep Longitudinal Coil	+/-1.5 amps	+/-1.5 amps	+/-1.5 amps
Water Requirements	2 gpm (min.) at 6 kW Input water temperature should be 60-70 F (15-21C) at a pressure of 60 psi (4.2 kg/cm ²), using a 3/8" (10mm) line.	3 gpm (min.) at 10 kW Input water temperature should be 60-70 F (15-21C) at a pressure of 60 psi (4.2 kg/cm ²), using a 3/8" (10mm) line.	3 gpm (min.) at 10 kW Input water temperature should be 60-70 F (15-21C) at a pressure of 60 psi (4.2 kg/cm ²), using a 3/8" (10mm) line.
Crucible Volume	Many options available	Many options available	Many options available

4

INSTALLATION

Required Components

See figure 3-B

The following is the minimum list of components required for setting up the source for safe operation.

- 1 High-voltage Feedthroughs** – Two high-voltage feedthroughs rated at 15 kV @ 70 amps. Bare copper straps are provided for use inside the chamber. Outside the chamber use #6 AWG copper wire with lugs for attaching feedthrough to transformer.
- 2 Tank Ground** – Use a solid copper strap or copper wire (#6 AWG or greater and up to seven strands, not copper braid) between tank and an 8 foot long copper clad steel grounding rod. Connections must be free of oxide and extremely tight.
- 3 Transformer Cover** – Mount filament (source) transformer as close to high-voltage feedthroughs as possible in the transformer box provided with the Telemark power supply.
- 4 Sweep Coil Feedthrough** – All sources, except models 221, 508 and 528, have an electromagnetic X-Y sweep coil and need a minimum of a four (4) pin low-voltage feedthrough. Kapton® coated wire is supplied on the standard coil connector Telemark #271-0125-1. Bare OFHC wire is used in the UHV assembly Telemark #271-0125-3. Coil connector assemblies come with two feet of wire standard, optional lengths are available. See figure 3-A for reference code of marked wires when shipped from the factory.

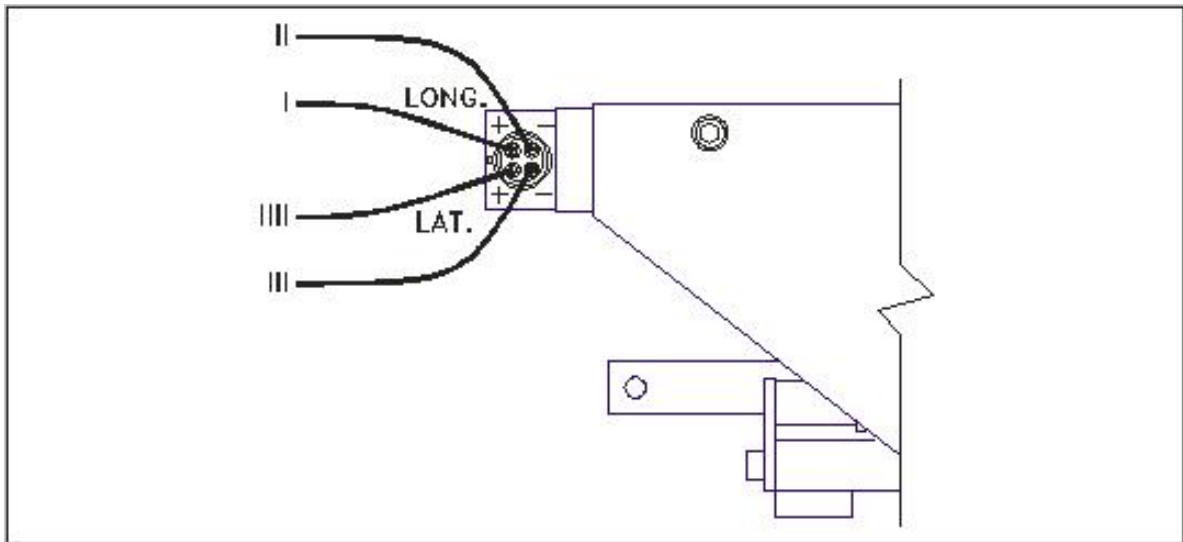

Figure 3-A Coil Wire Reference Code

- 5 Water Feedthrough** – For sources that do not come from the factory installed on flanges a water feedthrough is required. Use 3/8" O.D. x 1/16" wall 304 Stainless tubing and weld into fittings provided with source and butt-weld to tubing dual water feedthrough. We do not recommend the use of bellows inside the chamber. Attach feedthrough tubing to 3/8" copper tubing outside chamber, use compression fittings or other means to make this connection.
- 6 Water Filter** – Use standard removable water filter on inlet. Position away from chamber so that it is completely accessible for servicing.
- 7 Blowout Valve** – Use three-way valve attached to air or nitrogen supply for blowout.
- 8 Flowmeter** – Use a flowmeter with an interlock switch on water outflow.
- 9 Interlocks** – Install interlocks for Vacuum, Tank, High Vacuum, and Water. Other interlocks should be installed using the Aux interlock input.

Setting Up

Note that it is important to never use mild steel for electron beam source mounting. This includes mounting plates, standoffs or source shutter hardware. Mild steel could affect the magnetic properties of the electron beam source resulting in poor performance or a deformed electron beam. The best material to use is non-magnetic 304 stainless steel.

Set the source level with the required offset from chamber centerline. The source is easiest to operate and observe in operation if placed facing forward and in front of the

chamber centerline. The source may be mounted directly on a vacuum chamber baseplate, on stainless steel standoffs, a flange depending on the model and installation requirements. Custom designed mounting plates are available from the factory.

Good contact between the base of the electron beam source and the baseplate of the vacuum chamber is important to earth ground the source through the chamber baseplate.

A shutter should be mounted above and slightly behind the pocket. The shutter should obscure at least a one-hundred-degree cone above the pocket. A stainless disc makes a good, enduring shutter, provided it can be mounted ruggedly and detached easily for cleaning.

8 or 10 AWG copper wire is provided for the high voltage leads. These should be shortened to the smallest distance between source emitter and the feedthroughs, with a slight curve to allow for thermal expansion and contraction.

Interlocks should be installed, so that the breaking of any interlock turns off the source. See the note on high voltages below as to why this is important.

Grounding

Proper grounding is the single most important aspect of the installation of the E-beam. During arcing events, RF noise is generated that must be properly driven to ground to avoid interference/damage. For this reason, the E-beam ground must be separate from the electronics rack ground and ideally as short as possible. Improper grounding can lead to poor performance, interference with other equipment, damage to E-beam electronics or other equipment, or even shock potential.

Do not depend on water pipes for the system ground connection. Because of multiple joints and sealing compounds, water pipes typically do not make an earth ground. Keep in mind this is a high frequency as well as a DC ground.

Regardless of the method of grounding, the first point of connection for the ground cable/strap is always the E-beam chamber. There should be a specially designed ground bar welded to the chamber for this purpose. The strap, if used, should be "sandwiched" between two bars to ensure a broad area connection.

Connecting to Building Steel

The best method known for grounding the E-beam is to tie the ground bar to building steel as close as possible using the appropriate grounding strap (varies based on the distance - see details below). One must verify that the building steel has a good connection to ground for this to be a viable solution. Be sure to remove any paint, rust, etc from under the connection point to the building steel.

Because the connection is for an RF ground, surface area is more important than cross-sectional area. It is critical to have a wide surface area of connection between the grounding strap and the building steel.

Distance Between E-Beam Chamber and Grounding Point	Minimum Recommended Strap/Cable
< 10 Feet « 3 meters)	#6 Gauge or larger gauge copper cable
10-20 Feet (3-6 meters)	#4 Gauge or larger gauge copper cable
20-60 Feet (6-18 meters)	2 inch by .035 inch thick copper strap
> 60 Feet (> 18 meters)	Contact Telemark for recommendations

Table 4-1: Ground Strap Size

When in doubt, always go with the larger ground connection. You can never have too good of a connection!

Do not use braided wire. Be sure that the connection is made to clean metal.

The power supply is connected to ground using the HV cable's shield connection. The power supply may sustain major damage if power is applied before the ground is connected.

High Voltage

Use decals or other warning labels on the high voltage shield, at the front of the E-beam chamber and on the door to the room to provide warning that lethal voltages are present. Do not put any part of the body under a chamber while a source is running. Always use a grounding hook as a matter of habit before touching any potentially high voltage area, even when power supply is off. Always keep one hand in a pocket. Always maintain a respectful fear of high voltages: familiarity does not make high voltages safe.

Ground Connections

In addition to the critical building (earth) ground described above, there are 6 other ground leads that will be attached to the ground bar on the E-beam chamber:

1. Source Transformer Box - connected using 6 AWG gauge wire
2. E-beam power supply - connected using 6 AWG wire
3. Safety cover over high voltage feedthroughs - connected using 12 AWG gauge wire
4. Sweep controller - connected using 12 AWG gauge wire

5. TT-Controller - connected using 12 AWG gauge wire
6. Sweep cable ground connection - connected using 12 AWG gauge wire

There is not a required order for the above; simply connect each ground lead securely to an open ground lug location on the ground bar. Ensure connections are secure prior to turning on the power to the E-beam. Operating without one or more grounds properly connected may cause damage to equipment or even harm to the operator.

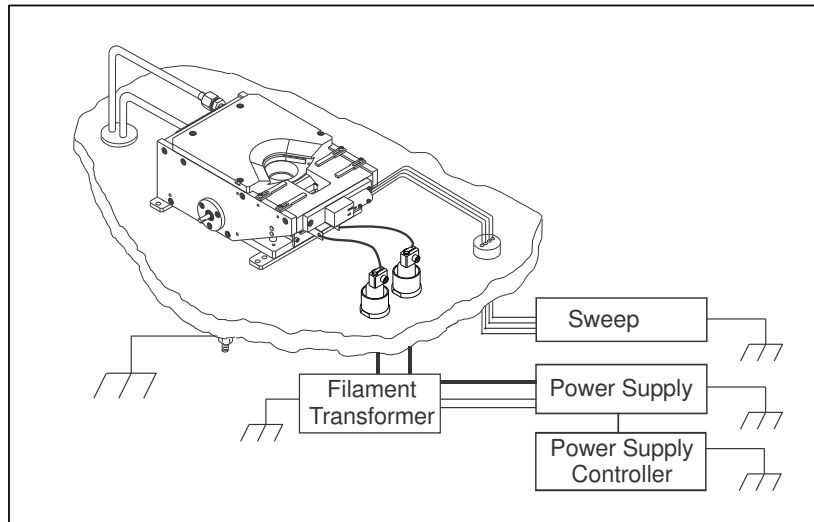

Figure 4-B Suggested Ground Installation

Two Source Installation

See Fig 3-C

To have a two-source installation work properly, a magnetic shunt bar must be placed between the two sources so that the magnetics of the sources do not interfere with the movement of positions of the dual electron beams. The shunt is usually a sandwich alternating between magnetic and non-magnetic metal with an air gap between each piece. Magnetic metals used are Mew metal or a mild steel .020 to .030 inch (0.50 to 0.75mm). Non-magnetic metals are non-magnetic stainless steel or copper .020 to .030 inch thick (0.50 to .75mm). One way of mounting the shunt to the magnet arms is with 304 stainless steel straps; other fastening methods may need to be used.

Sources must oppose each other for the sweep coils to work properly.

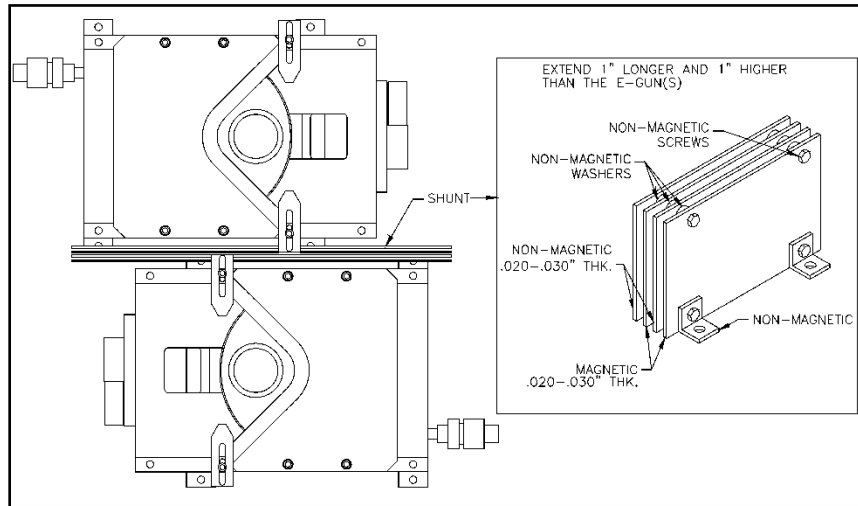

Figure 3-C Multi-Source Installation

5

OPERATION

General Operation – Startup

Load the crucible up to first rim with vacuum grade material. Make sure the view of the crucible is unobstructed from the view port when the chamber is closed. Welding glass (T9H is a convenient density) should be used when the beam intensity becomes too bright for direct viewing. (It is always a good idea to put a clean, removable piece of glass on the inside the chamber to prevent the port from being coated.) When the chamber is in operating range on the order of 1×10^{-5} torr or better, set the operation voltage, set the beam position to neutral, set the emission to zero, and reset the sweeps amplitude to zero.

When you are satisfied that conditions are optimal, turn on the power supply high voltage. Keeping an eye on the evaporant, very slowly turn up filament current. At around 100mA the beam should become apparent on the melt. If not, see the following paragraph. The beam should always be in the center of the crucible. As the emission is increased, the sweep pattern can be enlarged to cover the melt. After the ion gauge has stabilized and the material has stopped out-gassing and spitting, the shutter can be opened. After the required thickness level is reached, close the shutter, and reduce the emission to zero.

If the beam is not visible at 100mA of emission current, then adjust the beam position all the way in and then all the way out and from left to right. If the beam does not become visible at this time, do not under any circumstances try to increase the emission. Instead, turn off the source emission current and the high voltage. Check the longitudinal focus coil leads, be sure that they are not reversed, and go through the checklist under the section on troubleshooting.

General Operation – Shutdown

After terminating the final layer of the run sequence, turn down the filament current, turn off the high voltage, and allow the filament to cool for a few minutes before opening the chamber. The emitter assembly is surrounded by water-cooled components, so through radiation the filament will cool quickly. (A yellow oxide forms around the filament cavity if the vent is too fast.) Always use a grounding hook before working around high voltages.

Before removing the crucible for cleaning, make sure the water lines are blown out.

Adjusting the Electromagnetic Field

Position – The beam can be pulled towards the front of the crucible by:

- Reducing the high voltage (which also reduces beam intensity).
- Increasing the longitudinal coil current.
- Removing the shunt bar.
- Bringing the pole pieces farther in.

The beam can also be moved laterally by applying current to the lateral sweep coils.

Shape – As in the discussion above, the shape of the beam can be concentrated by bringing the pole pieces all the way in. In general, the beam shape is optimal for dielectrics if the pole pieces are two thirds of the way in, the shunt bar is added, and the accelerating voltage is around 6kV.

Intensity – The intensity of the beam is maximized by having the filament, beam former and anode plate aligned properly: see the service manual for your model electron beam source. If the intensity seems limited, the filament alignment should be checked – it may be warped, too far up, or even in backwards. The beam intensity is increased by turning up the filament current.

6

SERVICING

It is particularly important to be familiar with the removal and replacement of the crucible and the emitter, as these are the components most commonly removed for servicing.

Crucible Removal

Turn off the water and use the blowout valve to purge as much water from the source as possible. Undo the four Allen Head screws, holding down the cover plate, and remove the plate carefully; set it down on clean lint-free tissue to avoid contaminating it. Undo the crucible screws. Screw the thumbscrew provided into the center of the crucible and lift the crucible out. Take care when bead blasting or cleaning not to damage the O-ring surface.

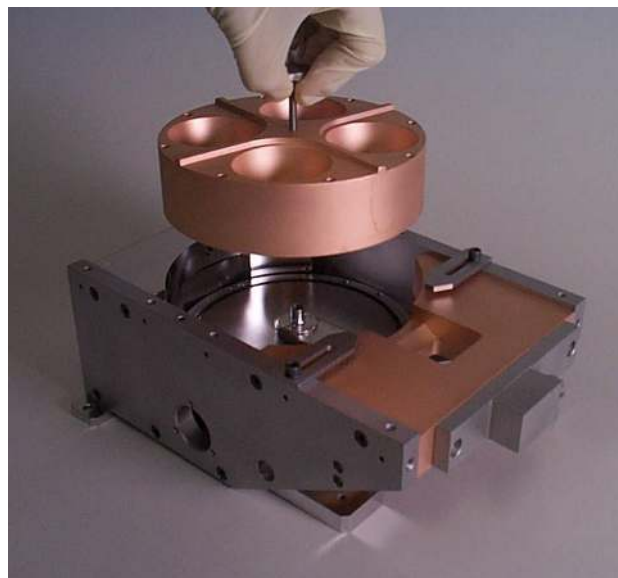

Photo 1 Crucible Removable

Crucible Replacement

Examine the crucible O-ring seating surface. If there are any major gouges, these should be fine sanded out. Make sure no flakes have fallen onto the O-ring during general system cleaning. Also, make sure no flakes get knocked onto the O-ring while lowering the crucible back on. Remove the thumbscrew. Tighten the crucible screws. Lower cover plate gently onto the arms and tighten the four holding screws. It is not necessary to relube any of these screw threads provided some lubricant remains from previous use. Turn on water, observing the sides of the cover plate and the base of the crucible for any leaks.

CAUTION: MAKE SURE THAT A GROUNDING HOOK IS USED TO SHORT ALL HV CONNECTION BEFORE ANY WORK IS PERFORMED ON THE EMITTER ASSEMBLY.

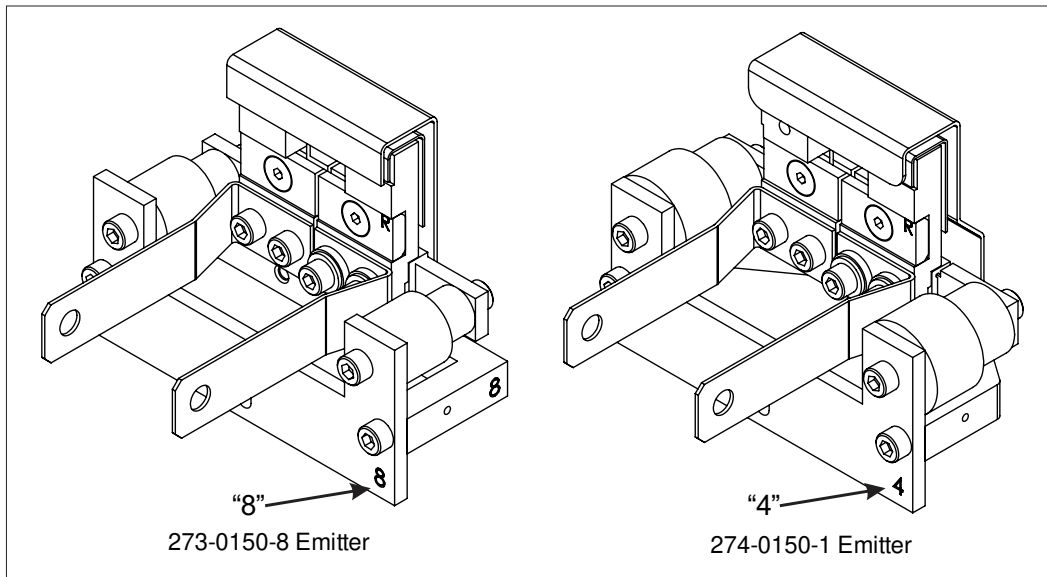

Figure 2-A Emitter Assembly

Starting in December 2018, all production sources (excludes Model 244) are being shipped with the 274-0150-1 Arc Suppression Emitter, which has a "4" stamped on the front surface of the mounting bracket and requires the above rebuild kit. If the emitter has an "8" stamped on the front surface of the mounting bracket, it is the legacy 273-0150-8 emitter, which requires the 273-0700-1 rebuild kit.

Emitter Removal

Remove the two nuts and bolts holding the filament buss bars to the high voltage leads. The emitter is attached to the base with a single #6-32 x 1/4" Allen screw. The most convenient way to detach the emitter assembly is with a long-handled Allen wrench (12" long is fine), since in normal practice the emitter is extremely hot at this time. Pull the emitter assembly straight out the front.

Emitter Disassembly and Cleaning

You will need several things for the disassembly/cleaning process:

- Alcohol to help free the tight screws.
- Wire to string the metal parts of your emitter for cleaning.
- A bead-blaster to clean the parts.
- Gloves to handle the parts while cleaning them using either alcohol or acetone.

Clean and vapor dry the parts after bead-blasting. Some of your ceramics can also be cleaned in this fashion. Discard any cracked or broken ceramics.

Filament Replacement

To replace the filament in the emitter assembly, it is necessary to locate and remove the two filament clamp screws. CAUTION: if the screws seem tight, you can use alcohol to keep them from seizing (See step 5 below).

Emitter Rebuilding/Reassembly

If the emitter is disassembled, refer to the pdf drawing and figure 2-B. Ninety percent of system problems during production relate to the EB-source emitter, so pay close attention to its assembly. It is of the utmost importance to trouble free runs.

In particular, pay meticulous attention to the following:

- 1** Length of screws. All screws must be clean and of the correct length. Tighten screws so that they are just snug. Do not overtighten screws going into or through ceramics. The ceramics will break, and the resulting loss of ceramics can be both frustrating and expensive.

- 2** The relative position of the anode plate, the beam former, and the filament must be precise to .005" (Refer to Figure 2-B). The filament (coils forward!) normally projects 1/2 of its diameter or slightly more (2/3) below the beam former. These dimensions are only a starting point. The clearance between these three elements should be judged based on experienced performance. The source will only work properly if these clearances are properly maintained.
- 3** Leads to filament. The voltage through the filament is only 12 volts, so filament clamps, leads and high voltage feedthroughs must all be snugged firmly (but not overtightened) to reduce resistance.
- 4** High voltage leads. Make sure the high voltage leads clear all the objects inside the chamber, especially the leads to the focus coil and the aluminum foil or other shielding, by at least one inch.

The following is the recommended step-by-step method to assemble an emitter. Note that you should not tighten the screws all the way down until instructed to do so.

- 5** Assemble the mounting bracket, the left-hand cathode block, and the left-hand buss bar using two #6 x 3/8" screws.
- 6** Add the following to the assembly: the L insulator, the right hand cathode block and the right hand buss bar, using two #6 washers, two collar insulators, and two #6 x 1/2" screws.
- 7** Mount the cross insulator and the beam former using one #6 x 1/4".
- 8** Stand this assembly up on a flat surface, with the buss bars facing away from you. Gently tap the beam former into place and snug the screw down. Turn the assembly so the buss bars are facing you. Press down gently on the beam former, and gently snug the screws on the right-hand buss bar. Check the gap between the two cathode blocks, making sure that they are parallel. Snug the left-hand buss bar screws.
- 9** Install the new filament, making sure that the filament orientation is correct (see figure 2-A). Using new #6 x 1/4" screws, loosely mount the filament clamps in place. Gently tap the emitter assembly on a flat surface to settle the filament into place. Slide the filament clamp on the right cathode block until it is flush with the right side of the block. Snug the right #6 x 1/4" screws. Gently push the left hand clamp into place. NOTE: Sliding this clamp can cause the filament to warp or bow. Snug the left #6 x 1/4" screws. Now check the alignment of the filament to the beam former.

- 10 Loosely mount two HV Insulators and two HV Shields to the emitter support bracket with two #6 x 3/8" screws.
- 11 Mount the Anode to the U Bracket using two #6 x 1/4" screws.
- 12 Attach the emitter support bracket assembly to the mounting bracket assembly, using two #6 x 1/4" screws. Place this assembly on a flat surface with the emitter support hanging over an edge. Gently push down on the support bracket and tighten the two #6 x 3/8" screws into the HV insulators. Next, carefully reach around and tighten the two #6 x 1/4" screws into the HV insulators. Now mount the U bracket assembly to the support bracket using two #6 x 1/4" screws. Gently push down on the mounting bracket and tighten the two #6 x 1/4" screws.
- 13 Push down on the Anode and tighten the last two #6 x 1/4" screws. Check the alignment of the Anode to the beam former (see figure 2-B). The rebuilt emitter assembly is now ready to be installed back in the EB-source.

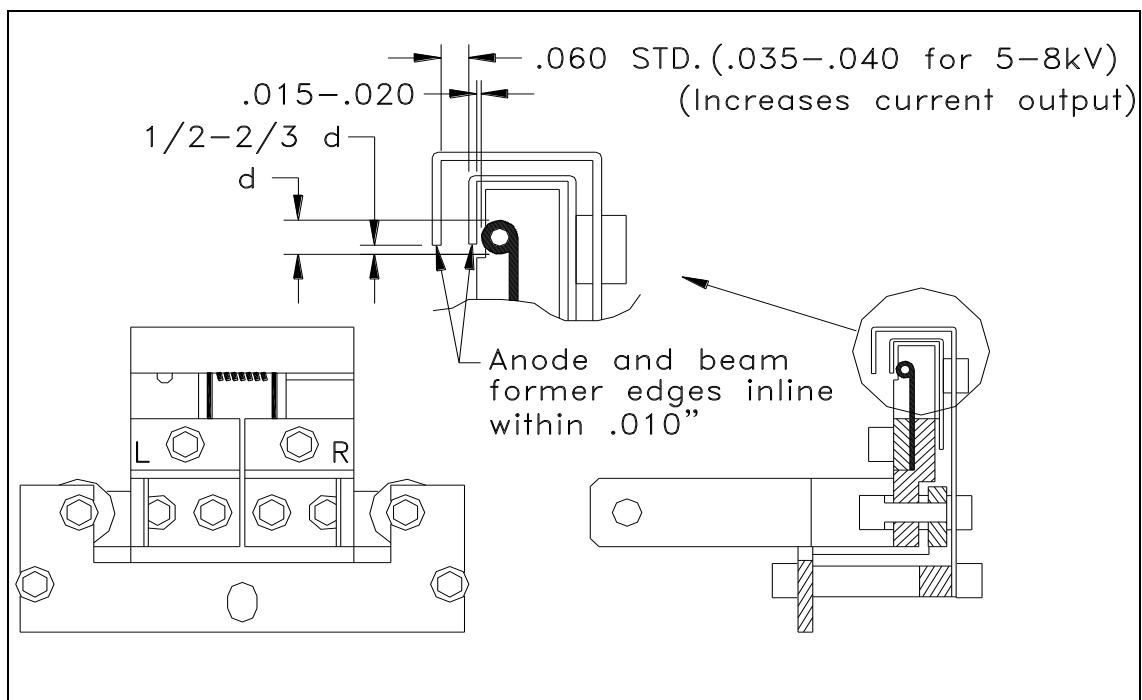

Figure 2-B Filament Location

Source Disassembly

When disassembling the source, the following steps help to maintain maximum gauss.

- 1 Turn off the water and blow out the water lines.
- 2 Remove the four screws from the cover plate and remove the cover plate.
- 3 Remove the screws holding down the crucible and use the thumb screw to lift the crucible from the source body.
- 4 Check the crucible O-ring, clean or replace as needed.
- 5 Clean the crucible and cover plate.
- 6 Turn the source upside down.
- 7 Remove the 4 screws that attach the crucible rotation assembly to the base plate.
- 8 Check the O-ring on the crucible rotation assembly, clean or replace as needed. See next section if crucible rotation assembly requires rebuilding.
- 9 Remove excess evaporant build up from the side arms and base plate with Scotch-Brite and clean with alcohol.
- 10 Reinstall the crucible rotation assembly with the 4 screws to the base plate.
- 11 Replace the crucible and tighten down.
- 12 Replace the cover plate and tighten down.

Note:
It is not recommended to bead blast assembly.
Removal of side arms will
reduce magnetic field (gauss)

Crucible Rotation Assembly

See the supplied pdf drawings and Photos 2, 3, 4, and 5

Check the bearings for free turning and make sure there is no vacuum grease in them. If there is, clean thoroughly, and, when dry, put in a very small amount of molybdenum disulfide.

Put the first bearings on the stem, put the housing over (with cut diameter on top), slip the second bearing in, lock it in with the retaining ring. Slip the gear over the cut diameter with the teeth down, lining up the holes (it should be a close fit).

At this point make sure the Quad-ring is clean, well greased, and installed without twisting in the crucible base plate. Carefully insert the crucible base on to the pivot shaft and push it all the way down onto the back of gear.

Have the four long Allen screws ready. Grasp the housing and the base together firmly and vertically, making sure the threads and holes line up. If you set them flat on a table, the base will fall off. Drop in the screws and tighten them. See photo 5. Put on the water duct (photos 6 and 7). Grease the O-ring lightly and mount the crucible.



Photo 2 Inserting the Crucible Base



Photo 3 Fastening the Crucible Base



Photo 4 Placing the Water Duct



Photo 5 Fastening the Water Duct

Crucible Quick Check

After Assembly:

- Make sure O-ring went in cleanly!

- Are long #6-32 housing screws tight? Check Water Duct clearance - is it parallel to base and clear of base and crucible?
- Does pivot shaft turn freely in crucible base?
- Attach rotary assembly to main body as in description on page 9.

Coil Assembly

The coil assembly is not intended to be separated from the front copper of the main body, partly because the magnetics are tested with the coils in place and could change if the coils are reassembled.

Side Drive Assembly

See supplied pdf drawings

Reassemble the side drive assembly by referring to the Side Drive Assembly pdf drawing. The pinion gear can be adjusted or tightened away from the main body without the need to peer under the crucible or try to awkwardly adjust the gear with a long-handled hex wrench.

To reattach the side drive assembly to the side arm, drop in three #10-32 x 5/16" Allen screws, and snug in housing. Check the engagement of the teeth. The teeth should line up and engage smoothly with about .015" play to allow for thermal expansion.

If adjustment is needed, remove the entire assembly and slide the pinion gear out or in as required.

Bottom Drive Assembly

See supplied pdf drawings

The bottom drive assembly must be assembled on the base of the source before the crucible rotation assembly is installed on the base of the source. It is designed with the proper alignment of the gears; there are no adjustments.

Main Body Reassembly

See supplied pdf drawings and Photo 6

When completely disassembled, after the components are cleaned, the main body of the source should be reassembled in the following order:

- 1 Install mounting straps.
- 2 Mount one magnet arm to the base plate, keeping the ends square and the bottoms flush. Snug the magnet arm to the base plate screws (Refer to photo 7).

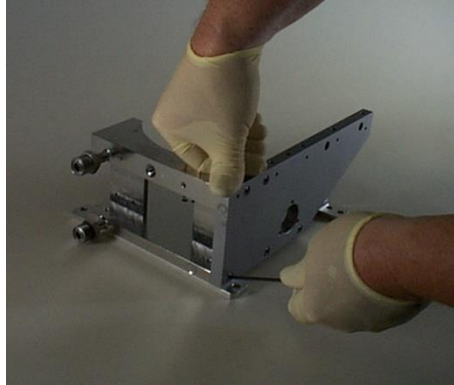

Photo 6 Fastening Magnet Arm

- 3 Place the magnet in the base plate, against the magnet arm, with "TOP" facing up (Note: with water lines facing you, south is on your right).
- 4 Attach the next magnet arm. Install the screws (tighten only the bottom screws to the base plate).
- 5 Tighten the 4 screws that attach the base plate to the rear shield half.
- 6 Tighten the remaining magnet arm screws.
- 7 Attach the crucible rotation assembly with the 4 screws.
- 8 Install the rear shield with 2 #10-32 screws.
- 9 Mount the crucible with the appropriate screws.
- 10 Install the cover.
- 11 Install the drive, side or bottom.
- 12 Install the emitter.
- 13 Your source is now ready to be regaussed.

Quick Check

If necessary use following check list which is used on final Q.A. to make sure everything is in place.

Emitter Assembly	Filament location	
	Anode, beam former and filament parallel	
	#6-32 screws snugged	
	Resistance check	Filament continuity
		Emitter to ground
	Fastened to baseplate	
Tightened firmly to HV leads		
Main Body Assembly	Screws tightened	Crucible
		Emitter
		Magnet arms
		Magnet shield
		Crucible cover plate
		Straps
	Stem	
Check magnet orientation! (From Rear of source, North on left, Top up)		
Magnetic Field	Checked directly Above filament: No current, 1 Amp applied	Longitudinal
		Lateral
Leak check	To 2×10^{-10} Std. ccs of helium	
Cleanliness	Beadblasting Flakes, dust, coating Fingerprints	
Waterline Fittings	Tight	

7

KITS AND ACCESSORIES

Installation Kits

One of the following Installation Kits is shipped with the EB Source.

244-0723-1 Installation Kit, 244

No.	Description	Quantity
241-5008-1	Thumbscrew, Crucible	1
244-0090-1	Shunt	2
244-2000-1	O-ring Kit	1
271-4004-1	Four-In-One Screwdriver	1
271-4020-1	Wrench Kit	1
273-0038-1	HV Lead Kit	1
273-0700-1	Emitter Parts Kit	1

264-0723-4 Installation Kit, 264

No.	Description	Quantity
264-2000-1	O-Ring Kit	1
265-0090-1	Shunt Bar	1
271-0043-2	Insertion Cone, HF	1
271-4004-1	Four-In-One Screwdriver	1
271-4020-1	Wrench Kit	1
271-5006-1	Thumb Screw, Crucible	1
273-0038-1	HV Lead Kit	1
274-0700-1*	Emitter Parts Kit	1

274-0723-4 Installation Kit, 273/274

No.	Description	Quantity
271-0043-2	Insertion Cone, HF	1
271-0090-1	Shunt Bar	2
271-4004-1	Four-In-One Screwdriver	1
271-4020-1	Wrench Kit	1
271-5006-1	Thumb Screw, Crucible	1
273-0038-1	HV Lead Kit	1
274-0700-1*	Emitter Parts Kit	1
274-2000-1	O-ring Kit, 273/274	1

294-0723-4 Installation Kit, 294

No.	Description	Quantity
271-0043-2	Insertion Cone, HF	1
271-4004-1	Four-In-One Screwdriver	1
271-4020-1	Wrench Kit	1
271-5006-1	Thumb Screw, Crucible	1
273-0038-1	HV Lead Kit	1
274-0700-1*	Emitter Parts Kit	1
294-0090-1	Shunt Bar	2
294-2000-1	O-ring Kit, 294	1
294-5006-1	Thumb Screw, Crucible	1

* Starting in December 2018, all production sources (excludes Model 244) are being shipped with the 274-0150-1 Arc Suppression Emitter, which has a “4” stamped on the front surface of the mounting bracket and requires the above rebuild kit. If the emitter has an “8” stamped on the front surface of the mounting bracket, it is the legacy 273-0150-8 emitter, which requires the 273-0700-1 rebuild kit.

Accessories

Recommended parts:

- 1 Power Supply** – We recommend the ST or TT power supplies from Telemark. However, this source will work well with all available power supplies that meet the operating specifications of the electron beam source.
- 2 High Voltage Covers** – Install two High Voltage Covers for each EB source.

No.	Description
275-0210-1	HV Cover Assy. Single Pass 1”
275-0210-2	HV Cover Assy. Single Pass 1.25”
275-0211-1	HV Cover Assy. Single Pass CFF

3 Indexer – Install one multi-pocket indexer for each EB source.

Model	Description
396-9901-1	Crucible Indexer, 1" Bolt
396-9901-2	Crucible Indexer, 1.25" Bolt
396-9901-3	Crucible Indexer, 4/6/Con. 2.75" CF Flange

4 Flowmeter – This Model uses ¼" NPT fittings and is rated at 1-6 gpm adjustable.

No.	Description
271-0831-1	Water Flow Switch, 110V

5 Shutter – For applications requiring a shutter install one of the following.

No.	Description
275-0888-1	Shutter/Controller, 1" feedthrough
275-0888-2	Shutter/Controller, 1-1/4" feedthrough
275-0888-3	Shutter/Controller, CFF 2.75" feedthrough

6 Feedthrough Kit – Install one of the following kits for each EB source.

275-0703-1 Feedthru Kit, Bottom Drive, 1"		
No.	Description	Quantity
275-0001-1	HV Feedthru, 1"	2
275-0002-1	Rotary 1/4 Feedthru, 1"	1
275-0003-1	Water Feedthru Assembly, 1"	1
275-0008-1	8 Pin Instrument Feedthru, Octal, 1"	1

275-0703-2 Feedthru Kit, Bottom Drive, 1.25"		
No.	Description	Quantity
275-0001-2	HV Feedthru, 1.25"	2
275-0002-2	Rotary 1/4 Feedthru, 1.25"	1
275-0003-2	Water Feedthru Assembly, 1.25"	1
275-0008-2	8 Pin Instrument Feedthru, Octal, 1.25"	1

275-0703-3 Feedthru Kit, Bottom Drive, CFF		
No.	Description	Quantity
275-0001-3	HV Feedthru, CFF	2
275-0002-3	Rotary 1/4 Feedthru, CFF	1
275-0003-4	Water Feedthru Assembly, 2-3/4 CFF	1
275-0008-3	8 Pin Instrument Feedthru, Octal, CFF	1

275-0704-1 Feedthru Kit, Side Drive, 1"		
No.	Description	Quantity
275-0001-1	HV Feedthru, 1"	2
275-0003-1	Water Feedthru Assembly, 1"	1
275-0006-1	Rt. Angle Rotary Feedthru, 1"	1
275-0008-1	8 Pin Instrument Feedthru, Octal, 1"	1

275-0704-2 Feedthru Kit, Side Drive, 1.25"

No.	Description	Quantity
275-0001-2	HV Feedthru, 1.25"	2
275-0003-2	Water Feedthru Assembly, 1.25"	1
275-0006-2	Rt. Angle Rotary Feedthru, 1.25"	1
275-0008-2	8 Pin Instrument Feedthru, Octal, 1.25"	1

275-0713-1 Feedthru Kit, Bottom Drive, Magnetic Seal, 1"

No.	Description	Quantity
275-0001-1	HV Feedthru, 1"	2
275-0003-1	Water Feedthru Assembly, 1"	1
275-0008-1	8 Pin Instrument Feedthru, Octal, 1"	1
275-0012-1	Feedthru, Rotary, Magnetic Seal, 1"	1

275-0713-3 Feedthru Kit, Bottom Drive, Magnetic Seal, CFF

No.	Description	Quantity
275-0001-3	HV Feedthru, CFF	2
275-0003-3	Water Feedthru Assembly, 2-3/4 CFF	1
275-0008-3	8 Pin Instrument Feedthru, Octal, CFF	1
275-0012-3	Feedthru, Rotary, Magnetic Seal, CFF	1

275-0714-1 Feedthru Kit, Side Drive, Magnetic Seal, 1"

No.	Description	Quantity
275-0001-1	HV Feedthru, 1"	2
275-0003-1	Water Feedthru Assembly, 1"	1
275-0008-1	8 Pin Instrument Feedthru, Octal, 1"	1
275-0016-1	Right Angle Rotary Ft, Magnetic Seal, 1"	1

Replacement Crucibles

Replacement crucibles are available to replace the crucible or to change number and size of the crucible pockets. When changing the number of pockets a new cover is required. In addition to standard crucibles, custom combinations of pocket sizes are available, please contact the factory.

Model 244 Crucibles

No.	Description
244-0240-1	Crucible, 4x 4cc
244-0245-1	Crucible, 4x 7cc
244-0270-1	Crucible, Trough 45cc
244-0281-1	Crucible, 6x 4cc
244-0282-1	Crucible, 6x 7cc

Model 264 Crucibles

No.	Description
264-0220-1	Crucible, 4x 25cc
264-0221-1	Crucible, 4x 30cc
264-0245-1	Crucible, 4x 7cc
264-0255-1	Crucible, 6x 15cc

264-0260-1	Crucible, 8x 7cc
264-0264-1	Crucible, 4x 15cc
264-0270-1	Crucible, Trough 190cc
264-0282-1	Crucible, 6x 7cc

Model 273 Crucibles

No.	Description
273-0258-1	Crucible, 6x 40cc
273-0270-1	Crucible, Trough, 383cc

Model 274 Crucibles

No.	Description
274-0209-1	Crucible, 4x 7cc
274-0210-1	Crucible, 4x 15cc
274-0220-1	Crucible, 4x 25cc
274-0221-1	Crucible, 4x 30cc
274-0227-1	Crucible, 4x 40cc
274-0245-1	Crucible, 6x 7cc
274-0255-1	Crucible, 6x 15cc
274-0257-1	Crucible, 6x 25cc
274-0260-1	Crucible, 8x 7cc
274-0261-1	Crucible, 8x 15cc
274-0270-1	Crucible, Trough, 275cc

Model 294 Crucibles

No.	Description
294-0210-3	Crucible, 4x 25cc
294-0215-3	Crucible, 4x 40cc
294-0225-3	Crucible, 6x 25cc
294-0230-3	Crucible, 6x 30cc
294-0235-3	Crucible, 6x 40cc
294-0240-3	Crucible, 8x 15cc
294-0245-3	Crucible, 8x 25cc
294-0260-3	Crucible, 12x 7 cc
294-0270-3	Crucible, Trough 440cc

Rebuild Kits

Seal Kits

244-2000-1 O-ring Kit, 244

No.	Description	Quantity
271-2010-1	O-Ring, Viton, ID 1/4", W 1/16"	1
271-2014-1	O-Ring, Viton, ID 1/2", W 1/16"	1
271-2110-1	O-Ring, Viton, ID 3/8", W 3/32"	2
271-2151-1	O-Ring, Viton, ID 3", W 3/32"	1
271-4206-1	Quad Ring, Viton, ID 1/2", W 1/8"	1

264-2000-1 O-ring Kit, 264

No.	Description	Quantity
271-2110-1	O-Ring, Viton, ID 3/8", W 3/32"	2
271-2122-1	O-Ring, Viton, ID 1-1/8", W 3/32"	1
271-2146-1	O-Ring, Viton, ID 2-5/8", W 3/32"	1
271-2247-1	O-Ring, Viton, ID 4-5/8", W 1/8"	1
271-4214-1	Quad Ring, Viton, ID 1", W 1/8"	1

274-2000-1 O-ring Kit, 273/274

No.	Description	Quantity
271-2110-1	O-Ring, Viton, ID 3/8", W 3/32"	2
271-2122-1	O-Ring, Viton, ID 1-1/8", W 3/32"	1
271-2146-1	O-Ring, Viton, ID 2-5/8", W 3/32"	1
271-2255-1	O-Ring, Viton, ID 5-5/8", W 1/8"	1
271-4214-1	Quad Ring, Viton, ID 1", W 1/8"	1

294-2000-2 O-ring Kit, 294

No.	Description	Quantity
271-2109-1	O-Ring, Viton, ID 5/16", W 3/32"	6
271-2110-1	O-Ring, Viton, ID 3/8", W 3/32"	2
271-2122-1	O-Ring, Viton, ID 1-1/8", W 3/32"	1
271-2261-1	O-Ring, Viton, ID 6-3/4", W 1/8"	1
271-4214-1	Quad Ring, Viton, ID 1", W 1/8"	1

Emitter Parts Kit for 273-0150-8 Emitter

273-0700-1 Emitter Parts Kit

No.	Description	Quantity
271-5003-1	Gloves, pr.	1
271-6010-5	Screw, #6-32 X 1/4" Slot Flat Head,Ti	2
271-6020-5	Screw, #6-32 X 3/16" Ti SHCS	1
271-6030-1	Vented Screw, #6-32 X 1/4" SST SHCS	4
271-6050-1	Vented Screw, #6-32 X 3/8" SST SHCS	6
271-6060-1	Vented Screw, #6-32 X 1/2" SST SHCS	2
271-6242-1	Flat Washer, #6	2
273-0001-1	Filament, 7-1/2 Turn	5
273-0003-1	Anode Plate	1
273-0004-2	Beam Former	1
273-0005-1	Insulator, Cross	1
273-0006-1	Insulator, Collar	2
273-0008-1	Insulator, L	1
273-0010-1	Insulator, HV	2
273-0011-1	HV Shield	2

Emitter Parts Kit for 274-0150-1 Emitter

274-0700-1 Emitter Parts Kit

No.	Description	Quantity
271-5003-1	Gloves, pr.	1
271-6010-5	Screw, #6-32 X 1/4" Slot Flat Head,Ti	2
271-6020-5	Screw, #6-32 X 3/16" Ti SHCS	1
271-6030-1	Vented Screw, #6-32 X 1/4" SST SHCS	4
271-6040-1	Vented Screw, #6-32 X 5/16" SST SHCS	2
271-6050-1	Vented Screw, #6-32 X 3/8" SST SHCS	4
271-6060-1	Vented Screw, #6-32 X 1/2" SST SHCS	2
271-6242-1	Flat Washer, #6	2
273-0001-1	Filament, 7-1/2 Turn	5
274-0003-7	Anode Plate	1
274-0004-7	Beam Former	1
274-0005-1	Insulator, Cross	1
274-0006-1	Insulator, Collar	2
274-0008-1	Insulator, L	1
274-0010-1	Insulator, HV	2
274-0011-1	HV Shield	2
274-0011-2	HV Shield, Large	2

HV Lead Kit

273-0038-1 HV Lead Kit

No.	Description	Quantity
119-0010-4	Copper Rod, OFHC, 8awg (0.125" x 12")	2
110-8404-1	Lug, Crimp Terminal, Ring, 8 Ga., 1/4	2
275-0119-6	Lug, Tin Pltd Copper 8awg #10 Non-Insulated Ring	2
271-6150-9	Screw, #10-32 X 1/2" SST SHCS	2
271-6255-1	Nut, #10-32, SST	2
271-6245-1	Flat Washer, #10, SST	4

Change Over Kit

When it is necessary to change the drive orientation of an existing EB source, one of the following kit supplies all the necessary parts.

No.	Description
244-0726-1	Change Over Kit, Bottom to Side Drive, 244
244-0728-1	Change Over Kit, Side to Bottom Drive, 244
264-0726-1	Change Over Kit, Bottom to Side Drive, 264
264-0728-1	Change Over Kit, Side to Bottom Drive, 264
274-0726-1	Change Over Kit, Bottom to Side Drive, 273/274
274-0728-1	Change Over Kit, Side to Bottom Drive, 273/274
294-0726-1	Change Over Kit, Bottom to Side Drive, 294
294-0728-1	Change Over Kit, Side to Bottom Drive, 294

8

TROUBLESHOOTING

This section should be read in conjunction with the section on assembling the emitter. Experience demonstrates that the emitter assembly causes ninety percent of system problems in production.

Power Problems

Problem: EMISSION CURRENT MUST BE TURNED TO HIGHER THAN NORMAL TO EVAPORATE.

Cause: Filament is badly warped or was put in backwards.

Correction: Remove emitter assembly and replace filament.

Problem: EMISSION GOES TO MAXIMUM WHEN THE HIGH VOLTAGE IS TURNED ON.

Cause: A flake of material (sometimes extremely small) may be shorting the filament block to the anode plate. This happens occasionally when heating brittle materials too fast.

Correction: Remove emitter, and try to locate and remove flake.

Problem: NO EMISSION CURRENT.

Cause 1: Filament is broken or leads need tightening

Correction: Replace filament or tighten connections.

Cause 2: Power supply filament control circuit is faulty. parallel

Correction: Fix power supply.

Problem: NO VOLTAGE.

Cause: System or source has high resistance ground

Correction: Check emitter, filament, and feedthroughs for shorts.

Beam Problems

Problem: NO BEAM VISIBLE IN CRUCIBLE AS CURRENT IS INCREASED.

Cause 1: The magnet was reversed when reassembling the source (this can have damaging affects on the EB source and chamber walls if emission current is increased too far while searching for beam).

Correction: Close down the system and reassemble the source with the magnet properly oriented.

Cause 2: The sweep unit may have a problem.

Correction: Check sweep for proper setup.

Problem: THE BEAM IS CENTERED TO THE FRONT OF THE CRUCIBLE, WITH NO COIL CURRENT.

Cause 1: The high voltage is below what the source was gaussed for.

Correction: Adjust the voltage so the beam is centered.

Cause 2: The magnet is too strong.

Correction: Place a shunt just behind the cover plate on the magnet arms to weaken the magnet.

Problem: THE BEAM CENTERED TO THE BACK OF THE CRUCIBLE, WITH NO COIL CURRENT.

Cause 1: The high voltage is above what the source was gaussed for.

Correction: Adjust the voltage so the beam is centered.

Cause 2: The magnet is too weak.

Correction: Remove shunts. If still out of position, contact factory to have the source regaussed.

Problem: THE BEAM DOES NOT HAVE THE DESIRED SHAPE.

Cause 1: The filament is warped or misaligned.

Correction: Replace the filament.

Cause 2: The pole pieces are either in or out too far.

Correction: Adjust the pole pieces.

Cause 3: The voltage is not set correctly causing the beam to spread out.

Correction: Adjust the voltage.

Problem: ARCING AND BLUE FLUORESCENCE OCCUR WHERE THE BEAM SHOULD BE.

Cause: The pressure is too high. There may be a water leak, the bleed valve may be wide open, or chamber seal may be broken.

Correction: Shut off the bleed valve, check the source or water fittings for leaks, check the most recently opened chamber seals (such as the door) for clean surfaces. Mentally and, if necessary, physically leak check chamber.

Rotation Problems

Possible problems with Quad-ring sealed Multi-Pocket Sources.

Problem: LOSS OF VACUUM WHEN THE CRUCIBLE IS ROTATED.

Cause: Water seal is letting water through.

Correction: Install a new Quad-ring.

Problem: THE CRUCIBLE IS DIFFICULT TO ROTATE.

Cause 1: The water seal is in need of lubrication.

Correction: Install a new Quad-ring.

Cause 2: The drive bearing is bad.

Correction: Check and replace bearing if needed.