



## PLC BASED Telemark CRYOCHILLER

---

### INSTRUCTION MANUAL



Models Covered in this manual 1200, 1800, 1800EXT, 2400, 3000, 3600, 4800

Copyright © Telemark Cryogenics, 1998-2026 – All rights reserved

Manual Rev 1.1.4 February 2026

[telemark.com](http://telemark.com)

Download the current version of this manual at

<https://telemark.com/water-vapor-cryochiller/cryochiller-models/>

Brand and product names are trademarks or registered trademarks of their respective companies

# TABLE OF CONTENTS

---

<b>1</b>	<b>INTRODUCTION.....</b>	<b>8</b>
1.1	SAFETY WARNINGS .....	8
1.2	WARRANTY .....	13
1.3	USER RESPONSIBILITY .....	14
1.4	INTENDED USE OF THE EQUIPMENT.....	14
1.5	STANDARDS .....	14
<b>2</b>	<b>SPECIFICATIONS .....</b>	<b>15</b>
2.1	GAS CWP CHART .....	19
2.2	ENVIRONMENTAL CONDITIONS .....	19
2.3	RECOMMENDED BREAKER AND WIRE SIZE .....	20
2.4	PHYSICAL DIMENSIONS.....	21
<b>3</b>	<b>INSTALLATION .....</b>	<b>22</b>
3.1	UNPACKING AND INSPECTION .....	24
3.2	SYSTEM PRESSURE .....	25
3.3	LOCATION .....	26
3.4	PANEL REMOVAL .....	26
3.5	WATER CONNECTIONS .....	27
3.6	REFRIGERANT LINE CONNECTION.....	29
3.6.1	Refrigerant Line Installation Notes.....	33
3.7	MAIN ELECTRICAL CONNECTIONS .....	35
3.7.1	Transformer Connections .....	37

- 3.8 REMOTE CONNECTIONS..... 38
  - 3.8.1 Analogue Output voltage .....42
- 3.9 ETHERNET/RS232/485 COMMUNICATION..... 42
  - 3.9.1 Ethernet (Laptop) set up .....45
  - 3.9.2 Commands Available when Using Ethernet, RS232/485 Control .....48
  - 3.9.3 Using TCPIP-RS232/485/Ethernet GUI .....50
- 4 OPERATION..... 52**
  - 4.1 CONTROLS AND DISPLAYS ..... 52
    - 4.1.1 Touchscreen .....52
  - 4.2 SCROLL PUSH BUTTON ..... 54
  - 4.3 PUSH BUTTONS ..... 54
    - 4.3.1 COOL Push Button(s)/Indicators(s).....54
    - 4.3.2 STOP/RESET Push Button.....55
  - 4.4 OPERATION ..... 55
    - 4.4.1 Turn on the main ISO isolator .....55
    - 4.4.2 Turning the Unit On.....55
    - 4.4.3 Standby .....56
    - 4.4.4 Cool .....56
    - 4.4.5 Defrost.....56
    - 4.4.6 Defrost Recovery Period.....56
  - 4.5 NORMAL OPERATING RANGES..... 56
- 5 TROUBLE SHOOTING GUIDE ..... 58**
  - 5.1 TROUBLE SHOOTING ..... 58
  - 5.2 REFRIGERATION LEAKS..... 58
  - 5.3 ALARM CODES/MESSAGES..... 58
  - 5.4 SAFETY SYSTEMS ..... 60
    - 5.4.1 Hardware Safety systems .....61
  - 5.5 TROUBLE SHOOTING GUIDE..... 61

5.6 THE USE OF “TOP-OFF” GAS CHARGES ..... 65

5.7 EMERSON (COPELAND™) COMPRESSOR ..... 66

    5.7.1 Compressor Diagnostics .....68

**6 DECOMMISSIONING..... 73**

**7 DESIGN OF CRYO-COILS ..... 75**

**8 CHINESE SAFETY DATA SHEET ..... 78**

## LIST OF FIGURES

Figure 3-1, Removing Unit from Transportation Pallet .....	25
Figure 3-2, Pressure Gauge .....	25
Figure 3-3, Service Panel .....	27
Figure 3-4, Water flow Requirements .....	28
Figure 3-5, Position of Hand Valve .....	29
Figure 3-6, Refrigerant Line Connections.....	30
Figure 3-7, Access Fitting .....	31
Figure 3-8, Refrigerant Manifold.....	32
Figure 3-9, Refrigerant Line Insulation .....	33
Figure 3-10, Metal O-ring Removal Tool .....	35
Figure 3-11, Main Isolator Wiring .....	36
Figure 3-12, Transformer Tapings.....	38
Figure 3-13, 37-Way Amphenol™ Connector, Front view .....	41
Figure 3-14, Digital Interface TCP/IP Connection .....	43
Figure 3-15, RS232/485 Wired by Customer .....	44
Figure 3-16, Communications Screen .....	45
Figure 3-17, Network Connection Window .....	45
Figure 3-18, Network Properties.....	46
Figure 3-19, TCP/IP .....	46
Figure 3-20, Set up for TCP/IP .....	47
Figure 3-21 RS232/485/Ethernet Command Screen .....	50
Figure 3-22, Write Commands .....	50
Figure 3-23, Read Commands .....	51
Figure 3-24, Read Responses and TCP/IP Commands.....	51
Figure 4-1, Front Panel Control .....	52
Figure 4-2, Discharge, Suction Pressure Display .....	52
Figure 4-3, Coil In, Coil Out, Circuit One Display.....	53
Figure 4-4, Coil In, Coil Out, Circuit Two Display, Dual Unit Only.....	53
Figure 4-5, Liquid Line Temp, Coldest Temp Display.....	53
Figure 5-1, “OVER PRESSURE” Alarm Message.....	59
Figure 5-2, “E2” With Fault Shown as “SP LOW” .....	59

Figure 5-3, "E6" With Fault Shown as "E6 COMPRESSOR ERROR" ..... 59  
Figure 5-4, "E8" With Fault Shown as "E8 CURRENT TRIP" ..... 60  
Figure 5-5, Emerson Compressor Front Panel Fault Code LED's ..... 67  
Figure 5-6, Emerson Compressor Internal Electronic Parts ..... 67

## LIST OF TABLES

---

Table 2-1, Model 1200, 1800, 1800EXT, 2400 Specifications.....	17
Table 2-2, Model 3000, 3600, 4800 Specifications .....	18
Table 2-3, Current Models Gas CWP Chart .....	19
Table 2-4, Environmental Conditions .....	19
Table 2-5, Recommended Breaker and Wire Size .....	20
Table 2-6, Physical Dimensions .....	21
Table 3-1, Cryochiller Recommended Circuit Breaker value and Wire Size .....	37
Table 3-2, Pin Connection for 37-way Amphenol Connector.....	40
Table 3-3, Write Serial Commands.....	48
Table 3-4, Read Serial Commands.....	49
Table 4-1, Display Mnemonics and Their Meaning.....	54
Table 4-2, Normal Operating Ranges .....	57
Table 5-1, Listing of Alarm Messages and Error Codes.....	60
Table 5-2, Troubleshooting Guide .....	65
Table 5-3, Emerson LEDs .....	72
Table 7-1, Coil Surfaces and Theoretical Pumping.....	76

# 1 INTRODUCTION

---

## 1.1 SAFETY WARNINGS

---



THE PHRASE WARNING IS USED WHERE THERE IS A HIGH PROBABILITY OF PERSONAL INJURY OR DEATH SHOULD THE PROVISIONS HIGHLIGHTED BE IGNORED. IT IS THE DUTY OF BOTH THE INSTALLER/OWNER AND OPERATOR OF THE EQUIPMENT TO BE FAMILIAR AND COMPETENT WITH THE OPERATION AND USES OF THE PRODUCT. HELP MAY BE SOUGHT FROM THE MANUFACTURER.

**WARNING**



- 1) The system contains specific hazards, which present a significant danger to personal safety:
  - (a) High voltage electrical components and high-pressure refrigerant gases, which are a significant frostbite hazard.
  - (b) Refrigerant gases, which will cause asphyxiation in confined areas.
  - (c) Refrigerant gases, which if exposed to high temperatures decompose to form very toxic by-products – never smoke in the vicinity of a UNIT or any other similar system including the gas cylinders.
  - (d) Water in close proximity to high voltage electricity.
  - (e) Hot and cold surfaces which represent a significant burn / frostbite hazard.

**WARNING**



The system contains gases under pressure, which may constitute both a frostbite hazard and a burn hazard. Refrigerant gases are known asphyxiates and are mildly narcotic. Precautions must be taken, and work must only be carried out by suitably qualified personnel.

**WARNING**



Removal of any panels other than the front door will expose the operator to high voltage components, which may result in a fatal electrocution.

**WARNING**



During installation there is the potential to be exposed to high voltage components (up to 400v ac), which may result in a fatal electrocution.

**WARNING**



Units must always be operated with a suitable ground/earth line. Failure to comply may result in fatal electrocution. Never tamper with or remove any ground/earth connection from inside of the machine.

**WARNING**



Isolate system before connection. Ensure the connection cable used is compliant with local electrical requirements. Cabling within the unit is tri-rated to CSA/UL/CE norms. There must be three power wires and one ground wire; there is no neutral line. Feed cable through gland and terminate at main system isolator, having first removed the protective cover. Ground the UNIT at primary ground point.

**WARNING**



Failure to replace isolator cover exposes operators to potentially fatal electrocution. It is essential this primary protection always be in place before the system is energized.

**WARNING**



Always isolate the system through the main circuit breaker before attaching the remote control. When in remote operation take additional care to prevent personal injury.

**WARNING**



Failure to leak test the system as a whole, may result in the catastrophic release of refrigerant, which presents a very high risk from frostbite and or asphyxiation. See emergency shutdown procedures and material safety data sheet for guidance.

**WARNING**



The refrigeration system contains a mixed blend of refrigerants and polio-ester oil. These do not present acute health risks, but it is essential that the following basic precautions are followed:

- a. Always wear eye protection.
- b. Always wear surgical type rubber or latex gloves.

**CAUTION**



The phrase “Caution” indicates a risk of damage to the product or associated plant and machinery if the provisions are not followed carefully.

**CAUTION**



Telemark will not be responsible or liable for either direct or consequential personal injury or loss claims arising from the misuse of the product.

**CAUTION**



If the equipment is used in a manner not specified by the manufacturer, the protection provided by the equipment may be impaired

**CAUTION**

It is the responsibility of the user to make sure all local, county, state and national codes, regulations, rules, and laws related to safety and safe operating conditions are met for each installation. The safety of any system incorporating the equipment is the responsibility of the assembler of the system.

**CAUTION - HOT SURFACE**

High temperatures are generated during normal operation. Avoid contact with exposed pipework as this can get hot during normal operation.

**CAUTION - COLD SURFACE**

Freeze Burn Risk. Very low temperatures generated during normal operation. Avoid contact with exposed pipework.

**CAUTION - PRESURISED GAS**

Unit contains pressurized gas. Do not open hand valves until the system is connected to a Cryo-coil, which has been checked for leaks. Do not connect the system to other systems unless their design and application has been approved by the manufacturer

**CAUTION - HAND VALVES**



**Closure of the hand valves while the system is at cryogenic temperatures may damage the valve seats and invalidate the system's warranty. It must only be attempted on a cryogenically cold system in case of an emergency, which is causing gross leakage from the Cryo-coil or refrigerant lines.**

## 1.2 WARRANTY

---

Telemark Cryogenics Cryochiller products are warranted to be free from defects in materials and/or workmanship under normal usage until warranty effective date listed on serial number label. Telemark Cryogenics' obligation under this warranty is limited to the repair or replacement, at its option, of any parts, which upon examination at the Telemark Cryogenics factory or by an authorized sales/service representative, shall appear to have become defective. Correction of defects by repair or replacement shall be either at the Telemark factory or in-situ by an authorized service representative. The location of repair shall be at the discretion of Telemark Cryogenics. Repairs carried out at Telemark Cryogenics factory shall be FOB Telemark factory and shall constitute fulfillment of obligations to the purchaser. All transportation costs for defective parts or products shall be borne by the purchaser. Telemark Cryogenics will not be liable for loss, damage, or other expenses directly or indirectly arising from the use of its products or from any other causes. Telemark assumes no liability for expenses or repairs made outside of its factory by non-authorized personnel.

All claims on account of defective material or workmanship shall be deemed waived unless made in writing within the warranty period. The foregoing warranty is in lieu of all other warranties expressed or implied. Telemark neither assumes nor authorizes any other person to assume any other obligation or liabilities in conjunction with the sale of its products. This warranty shall be void if the equipment has been subject to misuse, negligence, or application outside of the recommended operating environment or conditions. The warranty will also be invalidated if the identification numbers of the system have been altered, defaced, or removed.

The warranty is not intended to supplant any statutory rights the purchaser may have.

Unit start and end warranty dates are printed on the unit's serial number label.

## 1.3 USER RESPONSIBILITY

---

The user is responsible for proper installation, operation and ordinary maintenance of the equipment following the procedures in this manual. The warranty may be void if the equipment is improperly installed. Alteration of the design and or any function of the equipment voids the warranty and is entirely the responsibility of the user.

Telemark will not be held responsible or liable for either director consequential personal injury or loss claims arising from the misuse of the product. The user should read this manual in its entirety before carrying out any work and or operation of a Telemark Cryochiller.

## 1.4 INTENDED USE OF THE EQUIPMENT

---

Water vapor Cryochiller is a device that improves the performance of vacuum pumping due to the efficient trapping of water vapor in the chamber.

Classically a Cryochiller is used with an evaporative surface (Meissner/cryo-coil), which is located within the vacuum chamber. When in this configuration a Telemark Cryochiller is an ultrahigh performance vacuum pump capable of pumping water vapor and other condensable gases at speeds far more than conventional vacuum pumps.

A Telemark Cryochiller couples speed with a sophisticated computer control package which includes a simple and adaptable user interface with isolated inputs/outputs, RS232/485, and Ethernet TCP/IP comms package as standard.

The ranges of tasks to which your Cryochiller can be applied are not limited to pumping water vapor in vacuum. Many are used as substrate coolers (chuck coolers) or other applications where a continuous level of high-power cooling in the range –100 to –150oc is required.

## 1.5 STANDARDS

---

The device is compatible in terms of electromagnetic compatibility and safety standards.

Applicable standards:

**EMC:** DIRECTIVE 2014/30/UE - STANDARD EN 61326-1:2013

**LVD:** DIRECTIVE 2014/35/EU - STANDARD EN 61010-1:2011

And applicable causes of the standard: EN 378-2:2008

## 2 SPECIFICATIONS

---

Specifications for models 1200, 1800, 1800EXT, 2400, 3000, 3600 and 4800 are on the following pages.

	<b>Model 1200</b>	<b>Model 1800</b>	<b>Model 1800EXT</b>	<b>Model 2400</b>
Maximum Load (Watts)	1,200	1,800	1,800	2400
Typical Pumping Speed (l/sec)	65,000	100,000	100,000	135,000
Ultimate Vacuum	2 x10 <sup>-8</sup> mbar (2 x10 <sup>-6</sup> Pa)	2 x10 <sup>-8</sup> mbar (2 x10 <sup>-6</sup> Pa)	2 x10 <sup>-8</sup> mbar (2 x10 <sup>-6</sup> Pa)	2 x10 <sup>-8</sup> mbar (2 x10 <sup>-6</sup> Pa)
Weight (Kg)	193 (432 lbs.)	243 (536 lbs.)	243 (536 lbs.)	243 (536 lbs.)
Size inch (mm)				
L	24 (559)	24 (559)	24 (559)	24 (559)
W	22 (610)	22 (610)	22 (610)	22 (610)
H	59.5 (1511)	59.5 (1511)	59.5 (1511)	59.5 (1511)
Power supply	380-444VAC 3 ph. 50Hz 460VAC 3 ph. 60 Hz 200-230VAC 3 Ph 50/60 Hz	380-444VAC 3 ph. 50Hz 460VAC 3 ph. 60 Hz 200-230VAC 3 Ph 50/60 Hz	380-444VAC 3 ph. 50Hz 460VAC 3 ph. 60 Hz 200-230VAC 3 Ph 50/60 Hz	380-444VAC 3 ph. 50Hz 460VAC 3 ph. 60 Hz 200-230VAC 3 Ph 50/60 Hz
Wire/Cable Connection	3 Phase + Ground (Earth)	3 Phase + Ground (Earth)	3 Phase + Ground (Earth)	3 Phase + Ground (Earth)
Full Load Current draw @ 60 Hz (Amps)				
@200-230VAC	20	30	30	40
@380-440VAC	10	15	15	20
Start Up Max Current Draw @ 60 Hz (Amps)				
@200-230VAC	30	60	60	60
@380-440	15	30	30	30
Compressor Horsepower (HP)	4.5 (3.35kW)	7.5 (5.59kW)	7.5 (5.59kW)	10 (7.46kW)
Water Requirements (l/min)				
@ 15°C	5	5	5	6
@ 25°C	10	10	10	12
@ 32°C	20	20	20	30
Water Connections	All Models ¾" NPT Female			
Water Resistivity	All Models >0.1MΩ Chloride Free			
Water pH	All Models 6.5 - 8			
Refrigeration Connections	½" Metal Seal	½" Metal Seal	½" Metal Seal	½" Metal Seal
Max Coil Length (Meters) Using ½" Cu tube	20 (65.6 ft)	25 (82 ft)	25 (82 ft)	35 (114.8 ft)
Max Surface area (M2)	0.79 (≈8.57 ft2)	0.99 (≈10.72 ft2)	0.99 (≈10.72 ft2)	1.39 (≈15 ft <sup>2</sup> )
*Avg. Cool Time (mins)	2-5	2-5	2-5	2-5
*Avg. Defrost Time (mins)	2-4	2-4	2-4	2-4
ΔT Coil in/Coil Out (°C)	≈5	≈5	≈5	≈5

Digital Remote Connections Input Voltage range	18-24VDC (30VDC MAX)	18-24VDC (30VDC MAX)	18-24VDC (30VDC MAX)	18-24VDC (30VDC MAX)
Digital Remote Connections Output Voltage range	Relay contact closure 200 VAC or 100VDC Max at 300mA	Relay contact closure 200 VAC or 100VDC Max at 300mA	Relay contact closure 200 VAC or 100VDC Max at 300mA	Relay contact closure 200 VAC or 100VDC Max at 300mA
Balance Pressure Range as Shipped from Telemark USA facility (PSI) @20°C (hand valves closed)	270-300 (1.86-2.07MPa)	220-250 (1.51-1.72MPa)	220-250 (1.24-1.45MPa)	190-220 (1.31-1.52MPa)

**Table 2-1, Model 1200, 1800, 1800EXT, 2400 Specifications**

	<b>Model 3000</b>	<b>Model 3600</b>	<b>Model 4800</b>
Maximum Load (Watts)	3000	3,600	4,800
Typical Pumping Speed (l/sec)	165,000	200,000	275,000
Ultimate Vacuum	2 x10 <sup>-8</sup> mbar (2 x10 <sup>-6</sup> Pa)	2 x10 <sup>-8</sup> mbar (2 x10 <sup>-6</sup> Pa)	2 x10 <sup>-8</sup> mbar (2 x10 <sup>-6</sup> Pa)
Weight (Kg)	384 (845 lbs)	412 (930 lbs)	433 (955 lbs)
Size inch (mm)			
L	35.3 (897)	35.3 (897)	35.3 (897)
W	23.6 (897)	23.6 (897)	23.6 (897)
H	70.25 (1784)	70.25 (1784)	70.25 (1784)
Power supply	380-444VAC 3 ph 50Hz 460VAC 3 ph 60 Hz 200-230VAC 3 Ph 50/60 Hz	380-444VAC 3 ph 50Hz 460VAC 3 ph 60 Hz 200-230VAC 3 Ph 50/60 Hz	380-444VAC 3 ph 50Hz 460VAC 3 ph 60 Hz
Wire/Cable Connection	3 Phase + Ground (Earth)	3 Phase + Ground (Earth)	3 Phase + Ground (Earth)
Full Load Current draw @ 60 Hz (Amps)			
@200-230VAC	50	60	N/A
@380-440VAC	25	30	37
Start Up Max Current Draw @ 60 Hz (Amps)			
@200-230VAC	60	85	N/A
@380-440	30	45	60
Compressor Horsepower (HP)	13 (9.69kW)	15 (11.19kW)	20 (14.91kW)
Water Requirements (l/min)			
@ 15°C	6	8	10
@ 25°C	12	16	18

@ 32°C	30	30	32
Water Connections	¾" NPT Female		
Water Resistivity	All Models >0.1MΩ Chloride Free		
Water pH	All Models 6.5 - 8		
Refrigeration Connections	½" Metal Seal	½" Metal Seal	½" Metal Seal
Max Coil Length (Meters) Using ½" Cu tube	40 (131.2 ft)	50 (164.0 ft)	65 (213.3 ft)
Max Surface area (M <sup>2</sup> )	1.59 (≈17.1 ft <sup>2</sup> )	1.99 (≈21.42 ft <sup>2</sup> )	2.52 (≈27.13 ft <sup>2</sup> )
*Avg. Cool Time (mins)	2-5	2-5	2-5
*Avg. Defrost Time (mins)	2-4	2-4	2-4
ΔT Coil in/Coil Out (°C)	≈5	≈5	≈5
Digital Remote Connections Input Voltage range	18-24VDC (30VDC MAX)	18-24VDC (30VDC MAX)	18-24VDC (30VDC MAX)
Digital Remote Connections Out Voltage range	Relay contact closure 200 VAC or 100VDC Max at 300mA	Relay contact closure 200 VAC or 100VDC Max at 300mA	Relay contact closure 200 VAC or 100VDC Max at 300mA
Balance Pressure Range as shipped from Telemark USA facility (PSI) @20°C (hand valves closed)	250-280 (1.72-1.93MPa)	250-280 (1.72-1.93MPa)	260-300 (1.72-1.93MPa)

**Table 2-2, Model 3000, 3600, 4800 Specifications**



**IMPORTANT.** The above performance figures are based for a unit running at 60Hz mains power frequency. For units running on 50 Hz mains frequency the figures above need to be de-rated by 0.83.

## 2.1 GAS CWP CHART

---

<b>Current Production Models</b>			
-	<b>Mass (kg)</b>	<b>GWP</b>	<b>CO2 tons eq</b>
1200	2.94	3838	11
1800	3.50	3765	13
2400	3.56	3871	14
3000	5.55	4564	25
3600	5.15	4484	23
4800	7.97	5163	41
Top Off	0.83	5515	5

**Table 2-3, Current Models Gas CWP Chart**

## 2.2 ENVIRONMENTAL CONDITIONS

---

Environmental conditions for all models.

<b>Parameter</b>	<b>Value</b>
Type	Indoor use
Altitude	Up to 2000m
Temperature range (°C)	5 - 40
Humidity (%Rh)	Maximum relative 80% for temperatures up to 31 °C decreasing linearly to 50% relative humidity at 40 °C
Mains supply voltage fluctuations	Up to 10% of the nominal voltage
Pollution degree	2
Overtoltage category	II

**Table 2-4, Environmental Conditions**

## 2.3 RECOMMENDED BREAKER AND WIRE SIZE

---

Recommended circuit breaker values and wire size for cryochillers.

<b>200-230VAC Vac Three-Phase</b>			
<b>Nominal current rating[A]</b>	<b>Fuse Rating [A]</b>	<b>Minimum copper wire AWG/mm<sup>2</sup></b>	<b>Cable Type (recommended)</b>
30	70	8 / 10	H07RN-F 450/750V 4G10
50	100	6 / 16	H07RN-F 450/750V 4G16
60	125	4 / 25	H07RN-F 450/750V 4G25
<b>380-444VAC Three-Phase</b>			
15	30	14 / 2.5	H07RN-F 450/750V 4G2.5
25	45	10 / 6	H07RN-F 450/750V 4G6
30	60	10 / 6	H07RN-F 450/750V 4G6

**Table 2-5, Recommended Breaker and Wire Size**

## 2.4 PHYSICAL DIMENSIONS



Model	A (inch)	A (mm)	B (inch)	B (mm)	C (inch)	C (mm)
1200	22	559	24	610	59.5	1511
1800	22	559	24	610	59.5	1511
1800EXT	22	559	24	610	59.5	1511
2400	22	559	24	610	59.5	1511
3000	23.6	599	35.3	897	70.25	1784
3600	23.6	599	35.3	897	70.25	1784
4800	23.6	599	35.3	897	70.25	1784

Table 2-6, Physical Dimensions

## 3 INSTALLATION

Safety and Cautionary Notes for Installation.

**WARNING**



Failing to leak test the system may result in the catastrophic release of refrigerant, which presents a very high risk from frostbite and/or asphyxiation. See emergency shut down procedure and material safety data sheet.

**WARNING**



The system uses high voltage (208 or 415VAC) and high-power components. To avoid the possibility of a fatal electrical shock always isolate the unit from the mains supply before working on the system. A qualified technician, as for all high-power electrical connections, should carry out the electrical work

**WARNING**



The system contains gases under pressure, which may constitute both a frostbite hazard and a burn hazard. Refrigerant gases are known asphyxiants and are mildly narcotic. Precautions must be taken. Work must only be carried out by suitably qualified personnel. Always wear suitable eye protection

**WARNING**



All refrigeration work in which the refrigerant gas is moved or manipulated must be done by a qualified technician. Many national laws require individuals who perform such work to have a certification of Refrigeration Technician. Other laws in various countries might govern the use or service of this system. Local regulations should be strictly adhered to. Particular attention should be paid to containment and recovery of refrigerants.

**WARNING- TIP OVER RISK**



Use proper lifting equipment and protocols when removing the unit from the pallet

**WARNING – HEAVY OBJECT RISK**



Telemark Cryochillers weigh a minimum of 193Kg (432lb) and up to 412Kg (930lb). Failure to follow correct lifting practices may result in injury or death

**CAUTION – PRESURISED GAS**



Unit contains pressurized gas. Do not open hand valves until the system is connected to a Cryo-coil, which has been checked for leaks. Do not connect the system to other systems unless their design and application has been approved by the manufacturer, and they have been assessed for leak tightness

**CAUTION – ENVIROMENTAL RISK**



Do not release refrigerant into the atmosphere it is illegal and dangerous; please refer to your local authorities' instructions regarding the disposal of reclaimed refrigerants. Read the Material Safety Data Sheet before installing the system. Verify compliance to your local regulations.

### 3.1 UNPACKING AND INSPECTION

---

Before unpacking the unit, please verify that the packaging is in good condition.

The case is reusable and recyclable. Please treat the environment with respect. When removing the unit from the case ensure that any bags/boxes containing the refrigeration line connections, and other essential components are not discarded.

The unit is mounted to the pallet with four packing bolts. **The wooden pallet on which the unit is shipped must be removed prior to installation.**



**Note:** The unit must only be moved either by forklift truck or strapping through the forklift truck points located to the side of the unit.



**Figure 3-1, Removing Unit from Transportation Pallet**

### 3.2 SYSTEM PRESSURE

---

The unit is shipped fully charged. See Table 2-1, Model 1200, 1800, 1800EXT, 2400 Specifications and Table 2-2, Model 3000, 3600, 4800 Specifications for shipping pressure range of each model. The exact shipping pressure is noted on the packing list. A pressure gauge is mounted on the lower right-side panel by the water line connections. The static pressure may vary by up to +/- 16 psi due to changes in the ambient temperature.



**Figure 3-2, Pressure Gauge**

### 3.3 LOCATION

---

The unit should be placed on a clean level floor and positioned to minimize the length of the refrigeration lines. It is also important that the lines are well supported and are manufactured from annealed copper tubing allowing for thermal expansion and vibration. The units should be placed at least 3" (80mm) away from the nearest obstructions to allow for sufficient air flow to the unit.

### 3.4 PANEL REMOVAL.

---

Remove the front panel to gain access to "hand valve" gas box. Remove the 6 to 8 screws depending upon model, and remove the front panel exposing the hand valves. Remove the right-hand side panel where the isolator handle is located.



**Note:** the panel can only be removed with the isolator switch in the "OFF" position.

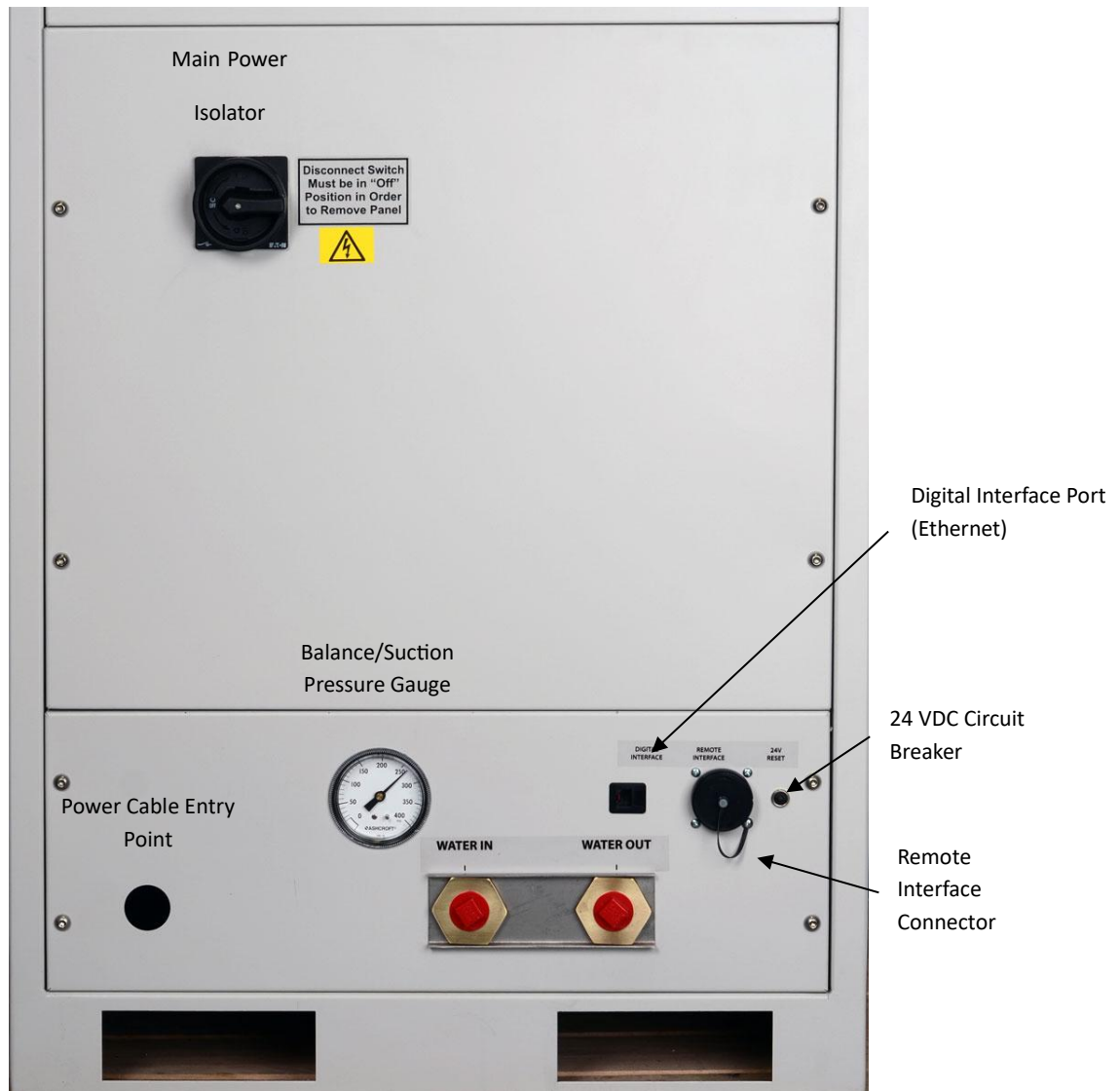

Figure 3-3, Service Panel

### 3.5 WATER CONNECTIONS

The advanced design of the unit means it can operate over a wide range of water temperatures. While Liquid Line temperature (LT on the display) is preset to 40°C maximum, there is little loss of performance with water (outlet – this is not displayed on the unit) temperatures as high as 35°C. Higher water temperatures result in a slight loss of capacity while water colder than 15°C will slow the systems response and lead to undue condensation on water lines.

In-house re-circulating water-cooling system is required. Water must be free from chlorides and sufficiently soft to prevent the buildup of lime scale (0.1 MΩ resistivity). Ensure that the water is clean and free from any clogging debris. The pH value should be between 6.5 and 8. The water inlet and outlet pipework need to have a minimum diameter of ¾ inch (20mm). The use of a suitable biocide can be beneficial when used in closed loop water systems.

Connect the water lines to the unit ensuring the correct orientation of the water lines (see Figure 3-3, Service Panel above). Turn on water flow and ensure no leakage is present at connectors. Open the cabinet and check visually for water leaks inside the cabinet.

Water temperature below ambient temperature may cause condensation. Additional insulation of the internal water lines may be required if the cooling water temperature is low and the ambient humidity is high.

The graph (Figure 3-4, Water flow Requirements) below indicates the cooling water flow required at varying inlet temperatures. As a practical limit, a flow rate of 30 l/min is approximately equivalent to a 15psi (1bar) pressure drop across the Unit.

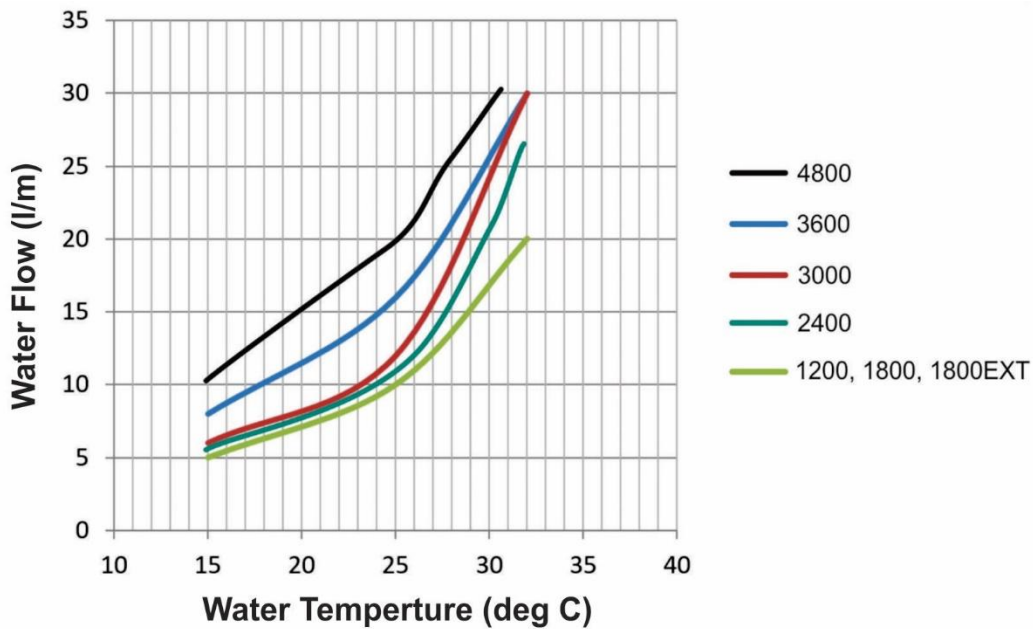

Figure 3-4, Water flow Requirements

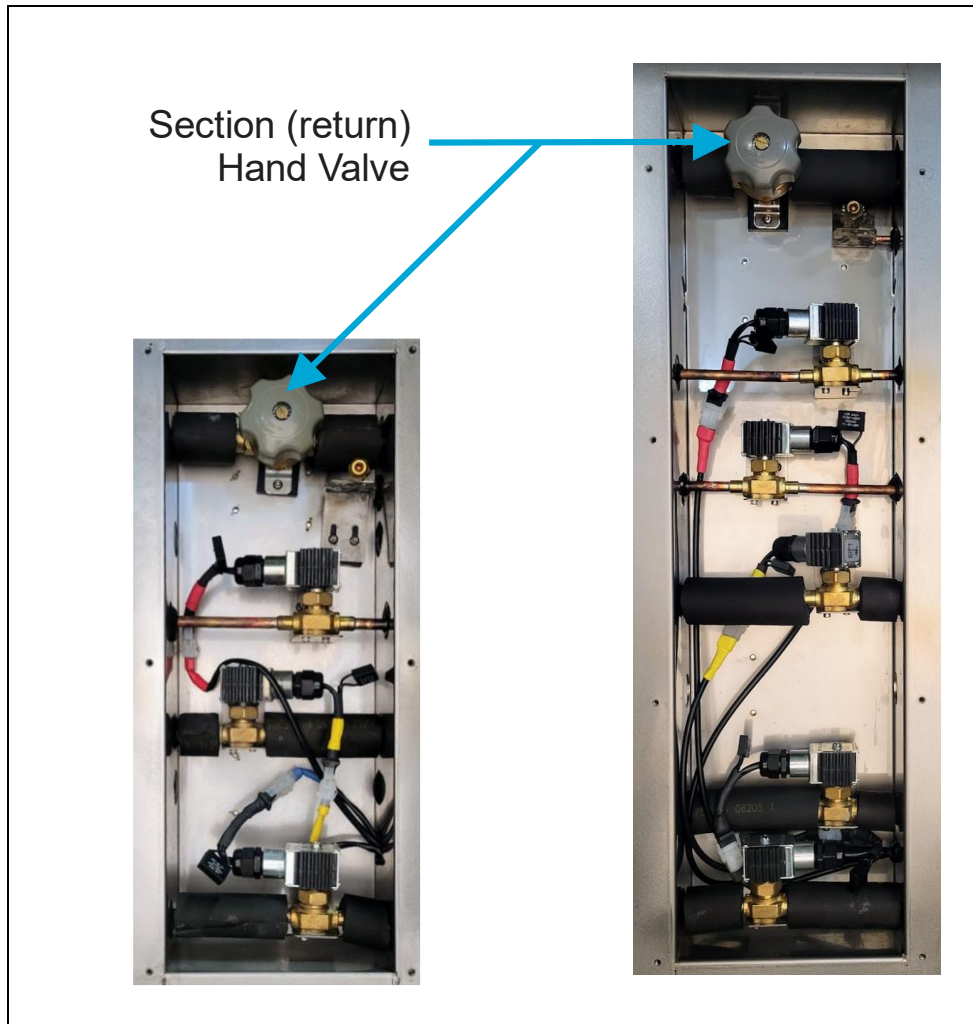

Figure 3-5, Position of Hand Valve

### 3.6 REFRIGERANT LINE CONNECTION

The refrigerant lines are connected to the unit using metal seal connectors. These need to be thoroughly checked to ensure that they are clean and free from debris, damage, or any other contaminants.



Note: If refrigerant lines manufactured/supplied by parties, other than Telemark Cryogenics, are being connected to the Telemark Cryochiller, ensure that the refrigerant lines meet the required specifications of the Cryochiller.

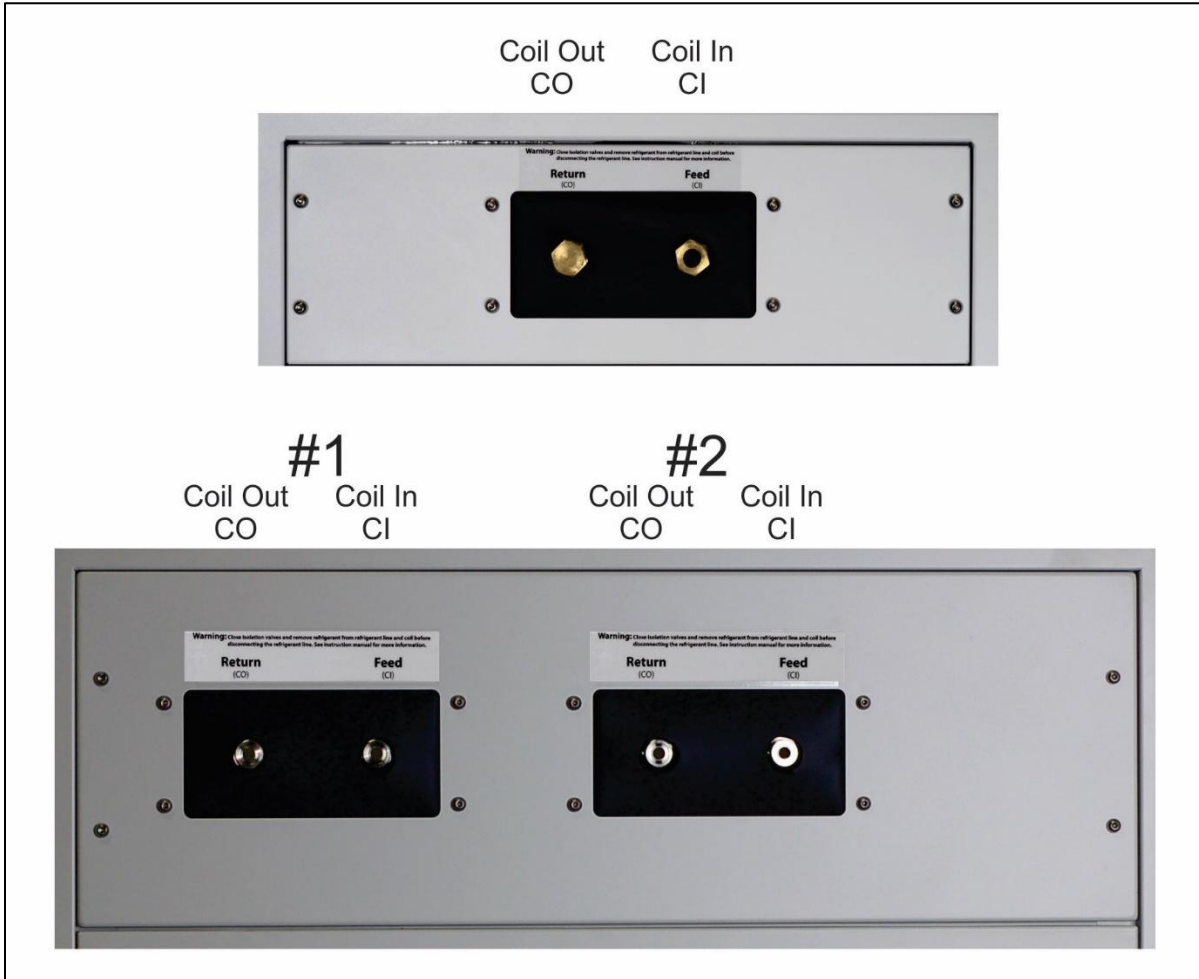

Figure 3-6, Refrigerant Line Connections

**CAUTION - HOT SURFACE**



High temperatures are generated during normal operation. Avoid contact with exposed pipework as this can get hot during normal operation.

**CAUTION - COLD SURFACE**



Freeze Burn Risk. Very low temperatures generated during normal operation. Avoid contact with exposed pipework.

Using new silver plated “O” seal (supplied in accessory Kit), carefully inset the O-ring s and mate the refrigerant line connection to the corresponding fitting. The “Coil In” (CI) is a ½” metal seal male fitting (from the unit to the Meissner coil) and the “Coil Out” (CO) is a ½” metal seal female fitting ( from the Meissner coil to the unit). Hand-tighten the nuts to ensure that the “O” seal is not displaced or damaged during the installation process. It is our recommendation that coupling fittings are fully tightened. Installation engineers must apply a torque of 70 ft/pounds (85-90n) on the couplings to minimize the possibility of leaking.

Using a set of Refrigerant Manifold gauges as shown below (Figure 3-8) connect inlet side of the manifold (center (yellow hose) to a bottle of dry Nitrogen or Argon and the high pressure outlet side of the manifold (red hose) to the units access fitting (see Figure 3-7).

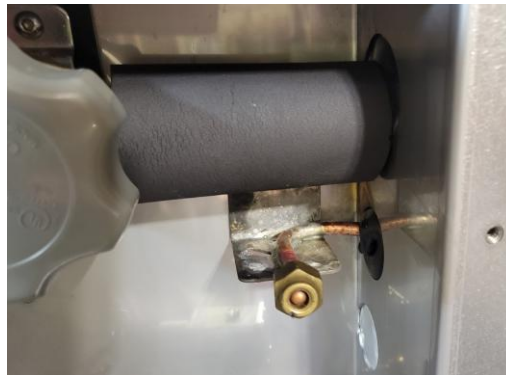

**Figure 3-7, Access Fitting**



**Figure 3-8, Refrigerant Manifold**

Open the access valve (see Figure 3-7) and pressurize the lines to 200 PSIG (13.78Bar (1.78Mpa)). Using a suitable liquid leak detection medium (soapy water) check the connections at both the Meissner coil and the Cryochiller ends for signs of leakage. The lines should be pressurized for at least 30 minutes while inspection is checked.



**Note:** When pressurizing the lines, **DO NOT** exceed the balance pressure in the Cryochiller.

When satisfied that the refrigerant lines connections are secure, carefully release the test gas using the refrigerant manifold. Re-check the metal seal connections to ensure that they are tight using the torque settings as per above.

Re-connect the refrigerant manifold so that the low-pressure side (blue hose) is connected to the access valve and the center yellow hose is connected to a suitable vacuum pump and evacuate the lines for at least 60 minutes.

Evacuate the refrigerant lines and cryo-coil through the system access fitting to 0.005 mbar or less. As evacuation refrigeration lines are severely conductance limited a minimum evacuation

time of at least two hours is recommended. Remove vacuum hose equipped with low loss fitting while the vacuum pump is still running. Close the common return hand valve and isolate the system before turning the vacuum pump off.

Re-fit the brass end cap ensuring that the copper seal is in place at access fitting.

Refit the valve access cover. Ensure that the seal around the valve access cover is properly secured and sealed. Failure to do so results in excessive moisture build up and ice.

### 3.6.1 Refrigerant Line Installation Notes

Refrigeration lines manufactured should conform to the following norms.	
Coil inlet line diameter	9.5mm – 3/8" to 15mm – 5/8"
Maximum recommended length	5m (15ft)
Coil outlet line diameter	15mm – 5/8" to 19mm – 3/4 "
Maximum recommended length	5m (15ft)
Minimum insulation	60mm of closed cell "Armaflex™"



**Note:** To maximize system performance, the refrigeration lines should be as short as possible



**Note:** Do Not repeatedly bend the refrigerant line as this will cause leakage and or breakdown of the insulation materials

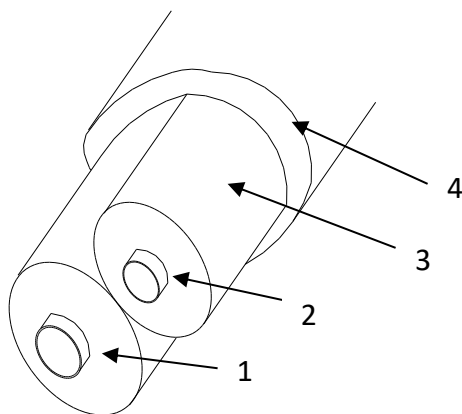

**Key**

- 1 line into unit from coil outlet (CO)
- 2 line from unit to coil inlet (CI)
- 3 1/2" wall 1/2" ID line insulation
- 4 1/2" wall 2-1/8" ID final insulation

Figure 3-9, Refrigerant Line Insulation

When installing the refrigerant lines, it is essential to protect the lines and fittings from the entrance of moisture, such as water vapor, which causes rapid degradation of any foam type insulation. An effective vapor barrier is best achieved by using the approved rubber-based impact adhesive followed by sealing of all glued edges with duct tape or 13mm electricians type PVC tape.

If the lines have visible frosting or condensation is seen leaking from them during defrost or standby, all the line insulation must be replaced.



All copper-to-copper joints must be silver or hard soldered, soft solder is unacceptable.

Inspect and clean all coupling faces. Ensure they are free from dents or scratches. Small imperfections on the couplings of the refrigerant lines may be rectified by using 1200 grade wet or dry mounted onto a glass plate. Special care needs to be taken when handling VCR fittings. It is critical that the faces are totally flat and square. Always purge lines through with dry nitrogen to prevent contamination of lines. When using the 1200 grade wet or dry ensure the abrasive pad is always dry.

It is recommended that the connections on the cryo-coil are male metal seal couplings (i.e. those with the O-ring groove) as these are more delicate than the female, flat face seal half of the coupling.

Position the refrigerant lines to suit the installation. Bend the refrigerant line, as necessary. The minimum bend radius is 12 inches (300mm). Ensure at least 5 inches (150mm) of straight line runs to the unit and to the feed-through coupling.



It is vital that a new O-ring is used every time a connection is made or broken. Always use the O-ring removal tool when removing the O-ring. Take care not to damage the mating surfaces of the connections. Metal O-ring Removal Tool is part No: 22-8000-18.



Figure 3-10, Metal O-ring Removal Tool

## 3.7 MAIN ELECTRICAL CONNECTIONS

---

Connect the 3-phase power and the ground to the main isolator.



**Note:** It may be required that the 3 phase connections must be altered to ensure the correct rotation of the compressor.

The unit does not require a neutral line; a circuit breaker with a value suitable for the maximum current draw must be selected and installed in the OEM vacuum equipment (see specification for current draw). The unit is phase sensitive and may require the phases to be swapped following initial start. The compressor is protected against reverse rotation and phase protection and will shut down automatically. The main power to the unit should be protected by a breaker located in the OEM system. The size of the breaker should be such to suit the amperage requirements of the Cryochiller being used. Please refer to Table 6 for sizing a suitable breaker.



**Note:** A suitable external switch or breaker may be required close to the equipment, check your local codes.

The mains power cable should be fixed in place using a cable strain relief gland so that the cable cannot be accidentally pulled from the unit. The “Power Cable Entry Point” size is 1 5/8” (approx. 41mm). The cable size used must meet local electrical installation regulations for the voltage and current of the unit.

Connect the power cable to the main isolator to the L1, L2 and L3 terminals and ensure that the ground (earth) wire is connected to the PE terminal. Tighten the terminals to 1.6 Nm (15.16 lb.-in).

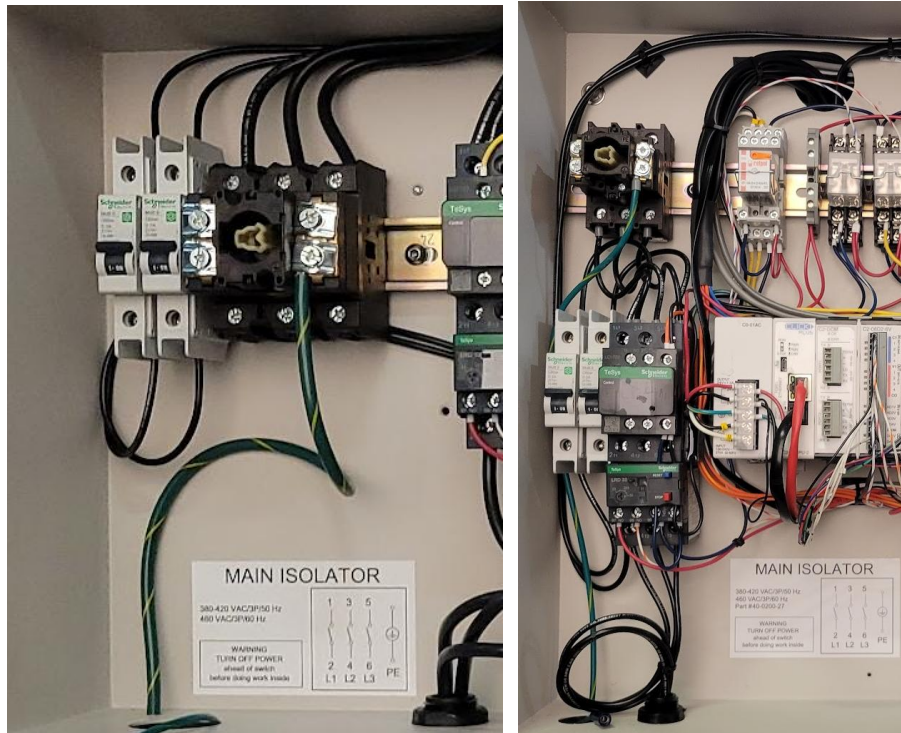

Figure 3-11, Main Isolator Wiring

<b>200-230VAC Vac Three-Phase</b>			
<b>Nominal current rating[A]</b>	<b>Fuse Rating [A]</b>	<b>Minimum copper wire AWG/mm2</b>	<b>Cable Type (recommended)</b>
30	70	8 / 10	H07RN-F 450/750V 4G10
50	100	6 / 16	H07RN-F 450/750V 4G16
60	125	4 / 25	H07RN-F 450/750V 4G25
<b>380-444VAC Three-Phase</b>			
15	30	14 / 2.5	H07RN-F 450/750V 4G2.5
25	45	10 / 6	H07RN-F 450/750V 4G6
30	60	10 / 6	H07RN-F 450/750V 4G6

Table 3-1, Cryochiller Recommended Circuit Breaker value and Wire Size

### 3.7.1 Transformer Connections

The units are manufactured as either “High Voltage” (HV) 380-420 VAC 3 phase 50/60Hz or 460 VAC 60Hz or “Low Voltage” (LV), 208-230VAC 3Phase 50/60Hz or 200VAC 60Hz



The voltage the unit is allocated at time of manufacture must be determined at time of order. Once ordered, the unit cannot be changed to operate using a different voltage.

A transformer is fitted to the unit to drop down the incoming voltage to 24VAC and 220VAC. It may be required that the voltage tapings on the transformer may have to be altered to suit the incoming mains voltage. For example, if the incoming voltage is 180VAC across two phases, the line side of the transformer needs to be connected to pin 2 of the transformer. If the incoming voltage is 230VAC across two phases, then the connection to pin 3 is required.

The illustration below gives details of the transformer connections.

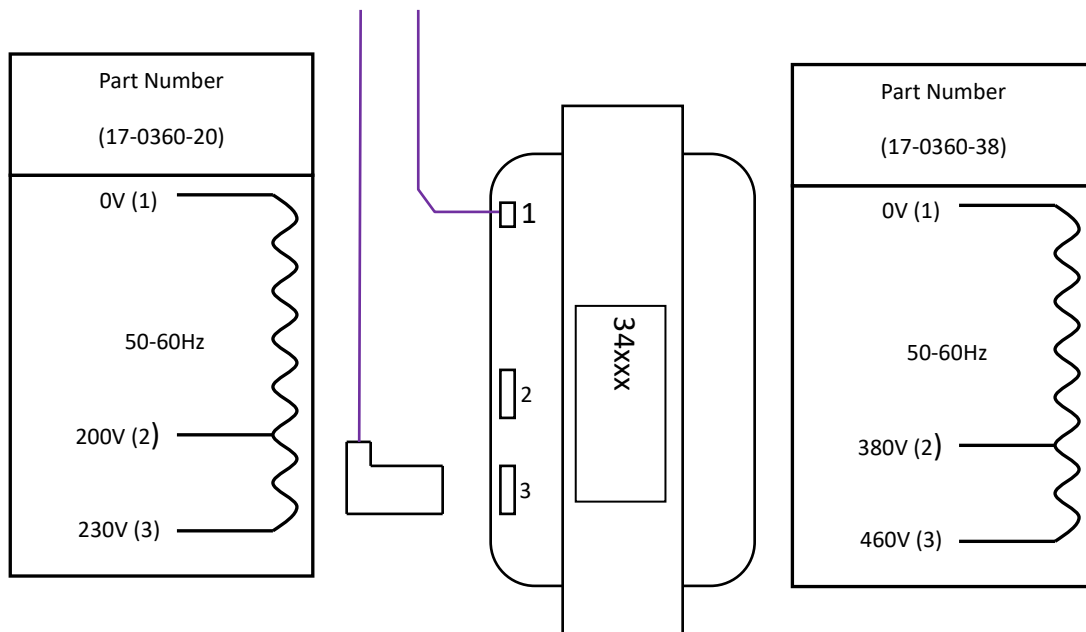

Figure 3-12, Transformer Tapings

### 3.8 REMOTE CONNECTIONS

Telemark Cryochillers can be controlled remotely using digital connections through a 37-way Amphenol socket, Ethernet TCP/IP, RS-232, or RS-485 serial communications. This section describes how to connect the unit remotely.

Digital Remote Control.

The inputs rely on a positive voltage (+24VDC )or AC 24 volt to the input reference to isolated ground (ISO GND) for an action to take place. When the signal is removed the Cryochiller will revert to its original state.

The digital outputs are via contact closures on relays. When a state is “TRUE” then the contact will close. The outputs can be configured so that the end user can either use the internal 24 VDC or use an external 24 DC or 24 AC voltage (indicate common) from the OEM equipment. Telemark recommends that the OEM use an external voltage for the “indicate” common.

The Digital output signals are always sent irrespective if the unit is in “Local” or “Remote” states.

The table below gives details of the 37-way connector pin functions

Pin	Input/Output	Description	Action
1	Input	Operate Unit	High input will start the UNIT. With Low input the UNIT will stop. UNIT must be in "remote operation" mode for this input to be active.
2		Isolated Ground	Common line for remote inputs.
3	Output	Indicate OK	Contact closure indicates that unit is OK and set to run process UNIT in LOCAL or REMOTE operation
4		Indicate Common	Indicate common for all output contact closures
5	Output	Indicate Power On	Contact Closure indicates that power present Signal present irrespective if UNIT in LOCAL or REMOTE operation
6		Indicate Common	Indicate common for all output contact closures
7	Not used		
8	Not used		
9	Input	Remote Operation	High input will put UNIT into remote operation. Low input will revert the UNIT into local mode
10	Output	Indicate Standby (1)	Contact Closure: Indicates that cooling circuit 1 is in "standby". Signal present irrespective if UNIT in LOCAL or REMOTE operation
11	Input	Operate Cool (1)	High Input: puts the UNIT cooling circuit 1 into COOL. Input low: reverts the UNIT to Standby mode. UNIT must be in "remote operation" mode for this input to be active.
12	Output	Indicate Cool (1)	Contact Closure: Indicates that cooling circuit 1 is in "COOL". Signal present irrespective if UNIT in LOCAL or REMOTE operation
13	Input	Operate Defrost (1)	High Input: puts the UNIT cooling circuit 1 into DEFROST. Input low: reverts the UNIT to Standby mode. UNIT must be in "remote operation" mode for this input to be active.
14		Isolated Ground	Common Line for remote inputs
15	Output	Indicate Defrost (1)	Contact Closure: Indicates that cooling circuit 1 is in "DEFROST". Signal present irrespective if UNIT in LOCAL or REMOTE operation
16	Output	Indicate Defrost Complete (1)	Contact Closure: Indicates that cooling circuit 1 has completed defrost. During Defrost the contacts will open. Signal present irrespective if UNIT in LOCAL or REMOTE operation
17		Indicate Common	Indicate common for all output contact closures
18	Not used		
19	Not used		
20	Output	Indicate Standby (2)	Contact Closure: Indicates that cooling circuit 12 is in "standby". Signal present irrespective if UNIT in LOCAL or REMOTE operation

21	Input	Operate Cool (2) (Dual circuit systems only)	High Input: puts the UNIT cooling circuit 2 into COOL. Input low: reverts the UNIT to Standby mode. UNIT must be in "remote operation" mode for this input to be active.
22	Output	Indicate Cool (2) (Dual circuit systems only)	Contact Closure: Indicates that cooling circuit 2 is in "COOL". Signal present irrespective if UNIT in LOCAL or REMOTE operation
23	Input	Operate Defrost (2) (Dual circuit systems only)	High Input: puts the UNIT cooling circuit 2 into DEFROST. Input low reverts the UNIT to Standby mode. UNIT must be in "remote operation" mode for this input to be active.
24		Isolated Ground	Common Line for remote inputs
25	Output	Indicate Defrost (2) (Dual circuit systems only)	Contact Closure: Indicates that cooling circuit 2 is in "DEFROST". Signal present irrespective if UNIT in LOCAL or REMOTE operation
26	Output	Indicate Defrost Complete (2) (Dual circuit systems only)	Contact Closure: Indicates that cooling circuit 2 has completed defrost. During Defrost the contacts will open. Signal present irrespective if UNIT in LOCAL or REMOTE operation
27		Indicate Common	Indicate common for all output contact closures
28	24VDC Output 1 (Reference is Isolated Ground)	Selectable: 1)COMP RUNNING 2)COIL OUT TEMP 3)COLD TEMP	User selectable output via "cal2309" setup. Signal present irrespective if unit in LOCAL or REMOTE operation. Settable ranges for "Relay Output 1" COIL OUT TEMP (CO) 0° to -130°C COLD TEMP (CT) -60°C to -130°C
29	Not used		
30	24VDC Output 2 (Reference is Isolated Ground)	Selectable: 1)COMP RUNNING 2)COIL IN TEMP 3)DEFROST ACTIVE	User selectable output via "cal2309" setup. Signal present irrespective if unit in LOCAL or REMOTE operation. Settable ranges for "Relay Output 2" COIL IN TEMP (CI) 0°C to -125°C
31	Not used		
32	Analog Output 1	Analog Out	Selectable to any pressure reading or temperature reading
33	Not used		
34	Analog output 2	Analog Out	Selectable to any pressure reading or temperature reading
35		24 Volt DC Out	24 VDC (250 mA max). Fuse 24 VDC output for use with remote operation
36		Ground (24 Volt DC)	Ground (GND) return for 24 VDC output for use with remote operation.
37	Not used		

**Table 3-2, Pin Connection for 37-way Amphenol Connector**

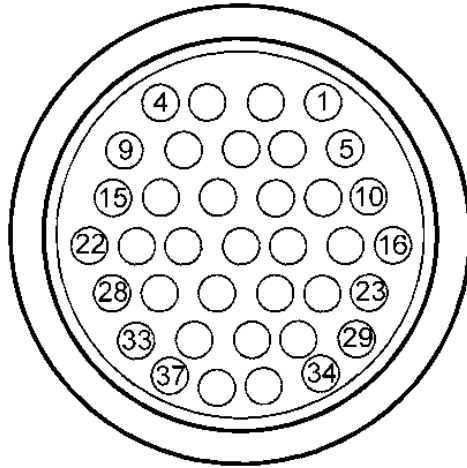

Figure 3-13, 37-Way Amphenol™ Connector, Front view

### 3.8.1 Analogue Output voltage

On pin 32 and pin 34 of the remote connector the analogue voltages are scaled as the table below.

Temp	Volts
30	
20	
10	
0	
-10	
-20	
-30	
-40	
-50	
-60	
-70	
-80	
-90	
-100	
-110	
-120	
-130	
-140	
-150	
-160	

The formula below can be used for the calibration of the analogue output voltage to temperature.

$$V=3.278 - (t / 31.22)$$

## 3.9 ETHERNET/RS232/485 COMMUNICATION

---

Telemark Cryochillers are capable of being controlled and data logged via an integral Ethernet port/RS232/485, this is accessible on the services panel diagram. This can be achieved using a

portable laptop or can be used via an Ethernet hub to interrogate the unit as well as send command functions. TCP/IP Software is supplied with the unit on a USB thumb drive.

The communication computer will need to be connected to the RJ 45 connector to the unit on the lower right side of the



Figure 3-14, Digital Interface TCP/IP Connection

RS232/485 ports can be wired by the customer to supplied connector if needed.

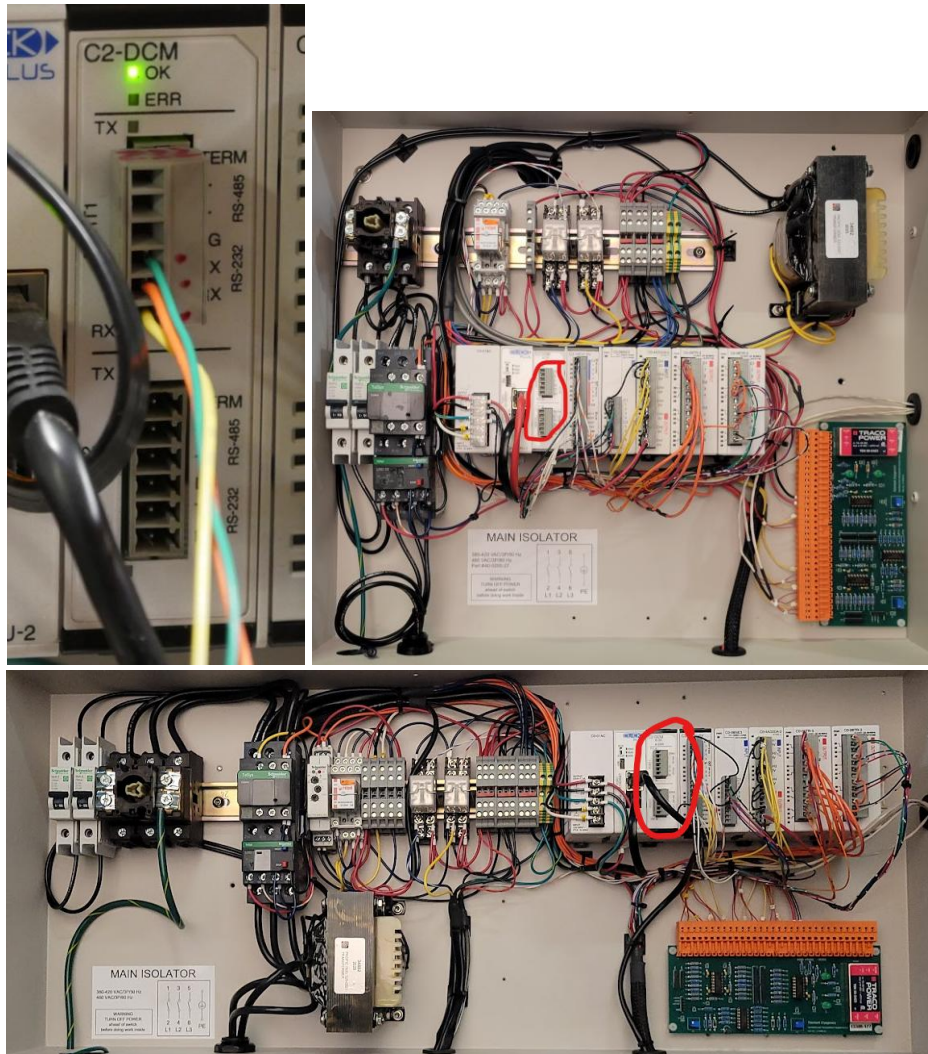

Figure 3-15, RS232/485 Wired by Customer

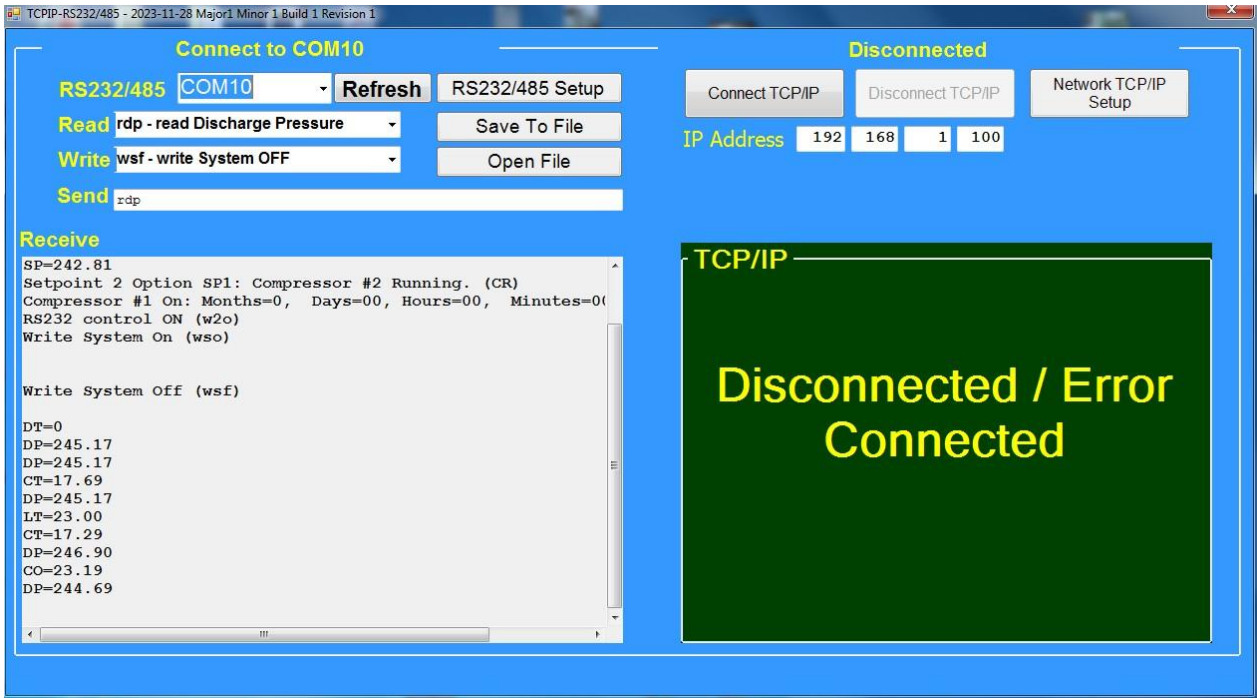

Figure 3-16, Communications Screen

### 3.9.1 Ethernet (Laptop) set up

Install the software sent with the unit. The software is self-extracting and then follow the on-screen instructions. Once the software has installed open “Network Connections”

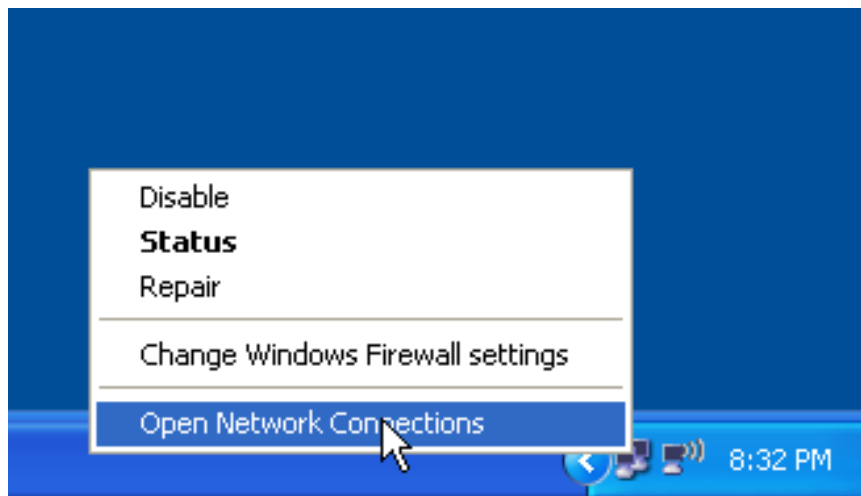

Figure 3-17, Network Connection Window

Right Click on Local Area Connection and then click on Properties.

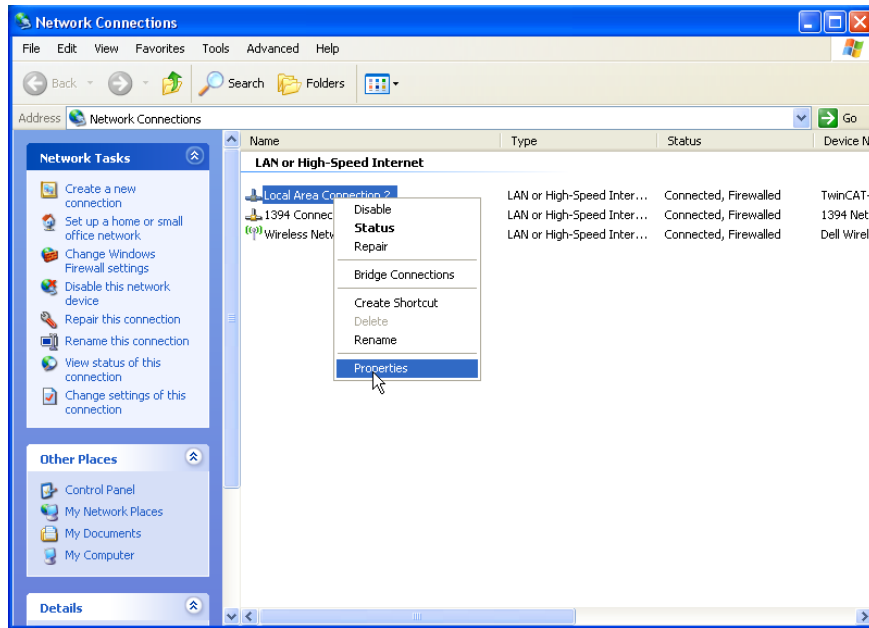

Figure 3-18, Network Properties

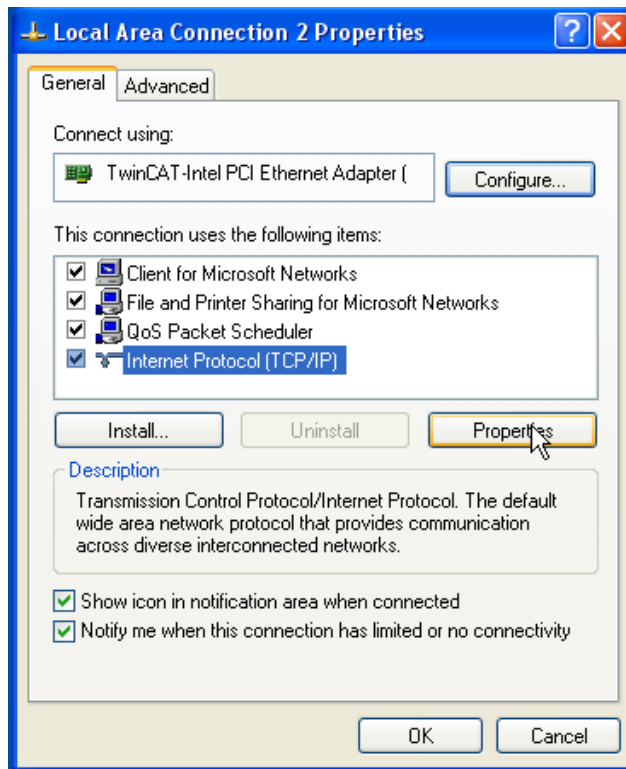
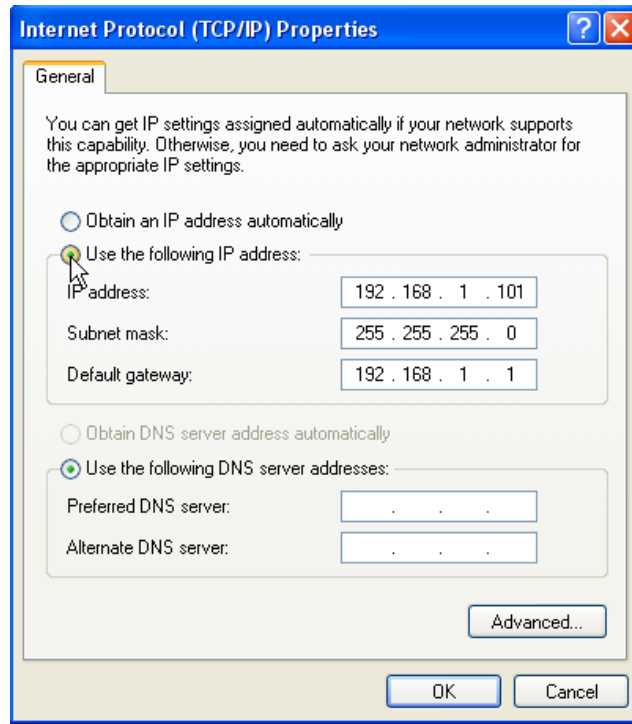

Figure 3-19, TCP/IP



**Figure 3-20, Set up for TCP/IP**

Power up system and wait 10 seconds or so and then open the software supplied on the USB thumb drive.

### 3.9.2 Commands Available when Using Ethernet, RS232/485 Control

Command	Command Type	Operation
w2o	Write	Turns TCP/IP Communications link on
w2f	Write	Turns all communication links off
wso	Write	Turns the Unit on (compressor running)
wsf	Write	Turns the unit off (turns the compressor off)
wss	Write	Puts coil #1 into Standby
w2s	Write	Puts coil #2 into Standby
wsc	Write	Puts Coil #1 into cool
w2c	Write	Puts Coil #2 into cool
wsd	Write	Puts Coil #1 into defrost
w2d	Write	Puts Coil #2 into defrost
v	Write	Start the data logging function (TCP/IP GUI)
q	Write	Stop the data logging function (TCP/IP GUI)
?w	Write	Displays "write" commands (list format)
?r	Write	Displays "read" commands (list format)

**Table 3-3, Write Serial Commands**

Command	Command Type	Operation
rdp	Read	Reads the Discharge Pressure
rsp	Read	Reads the Suction Pressure
rci	Read	Reads the Coil In (CI) temperature
rco	Read	Reads the Coil Out (CO) temperature
rlt	Read	Reads the Liquid Line (LT) temperature
rct	Read	Reads the Coldest (CT) temperature
ri2	Read	Reads the Coil In #2 (CI#2) temperature (dual coil units only).
rc2	Read	Reads Coil Out #2 (CO#2) temperature (dual units only).
rls	Read	Reads the Liquid line shut down temperature.
rdt	Read	Reads the Defrost Termination Temperature.
rpr	Read	Reads the set Point 1 relay temperature.
rp2	Read	Reads the set point 2 relay temperature.
rh1	Read	Read Compressor #1 on hours running.
rh2	Read	Read Compressor #2 on hours running (if fitted).
rsn	Read	Reads the unit's serial number.
rsr	Read	Reads the software Revision.
rip	Read	Reads the current IP address.

**Table 3-4, Read Serial Commands**



**Note:** “write” commands are case sensitive.

### 3.9.3 Using TCPIP-RS232/485/Ethernet GUI



Figure 3-21 RS232/485/Ethernet Command Screen

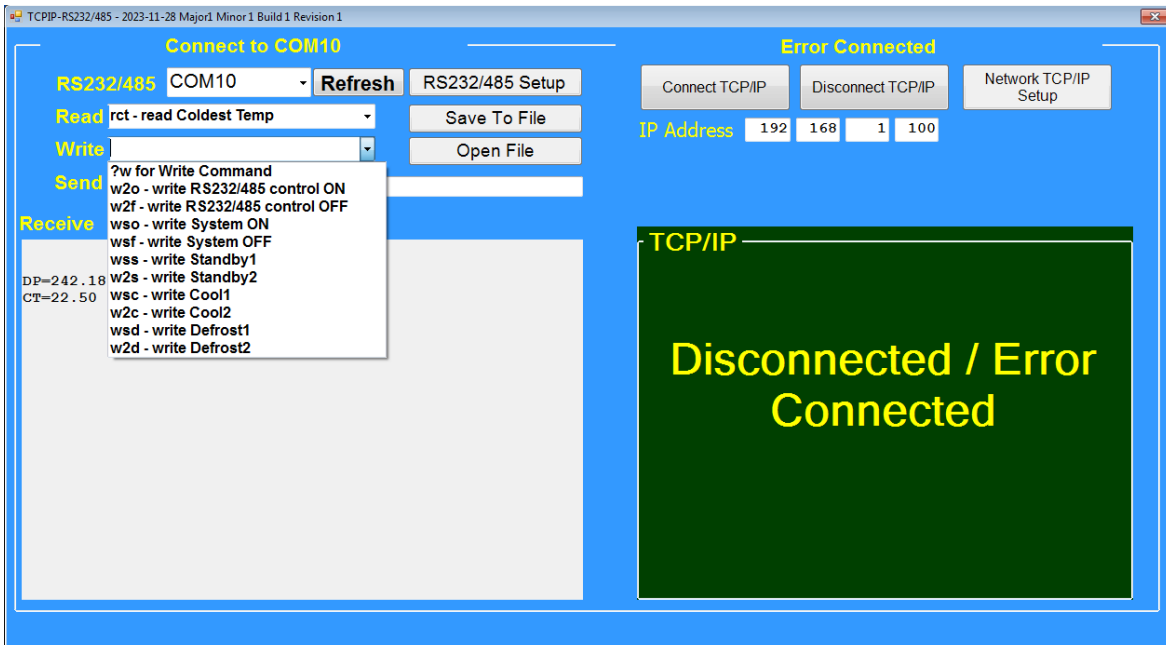

Figure 3-22, Write Commands

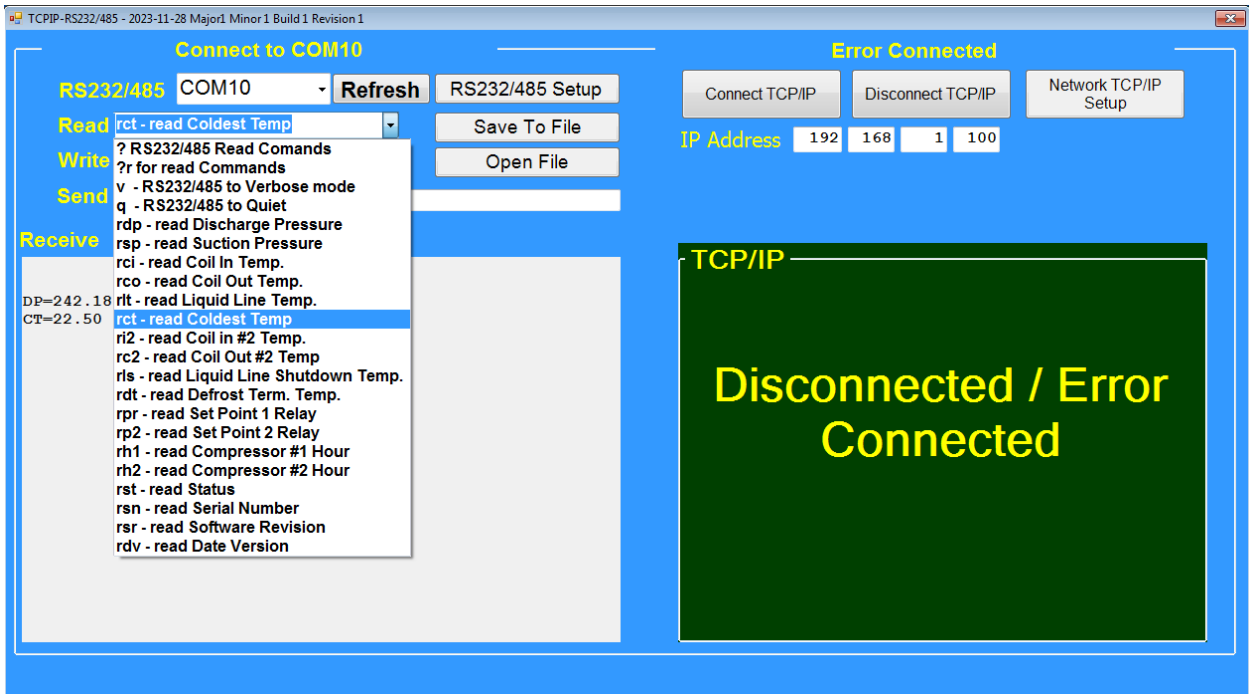

Figure 3-23, Read Commands

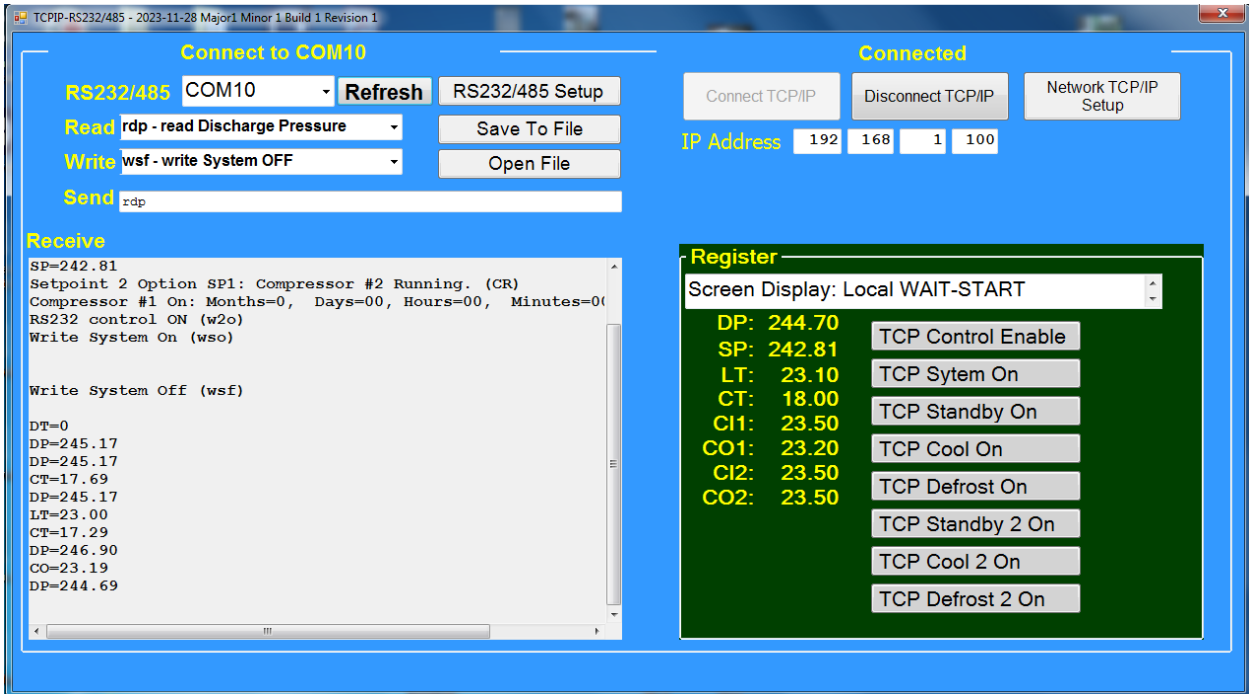

Figure 3-24, Read Responses and TCP/IP Commands

## 4 OPERATION

The operations below describe how to operate the unit in manual mode. For remote operation please refer to section 0 of this manual.

### 4.1 CONTROLS AND DISPLAYS



Figure 4-1, Front Panel Control

#### 4.1.1 Touchscreen

Displays the status of the unit as well as, the current running parameters. It also displays any alarm conditions that may be present. Alarm conditions will be described in the trouble shooting section of this manual (Chapter 5)

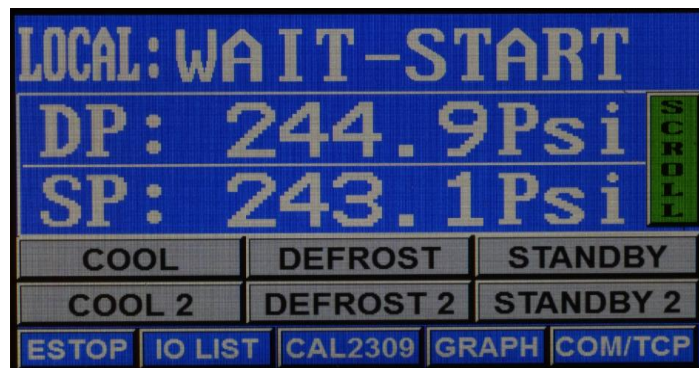

Figure 4-2, Discharge, Suction Pressure Display



Figure 4-3, Coil In, Coil Out, Circuit One Display

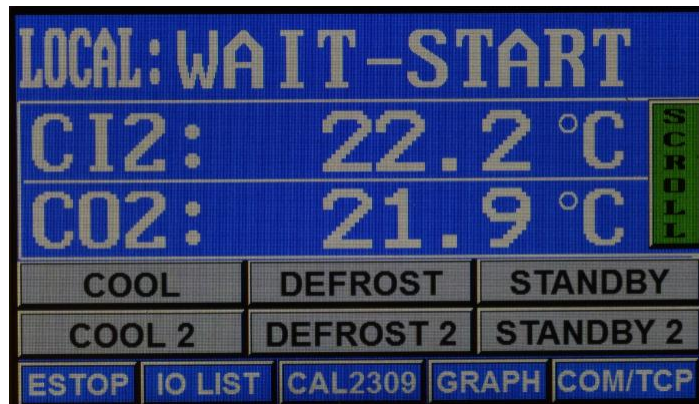

Figure 4-4, Coil In, Coil Out, Circuit Two Display, Dual Unit Only



Figure 4-5, Liquid Line Temp, Coldest Temp Display

Display character mnemonic	Meaning	Units
DP	Discharge pressure	Psi
SP	Suction pressure	Psi
CT	Coldest system temperature (internal measurement)	°C
LT	Liquid Line Temperature	°C
CI	Coil in (outlet / flow from unit) temperature	°C
CO	Coil out (inlet / return to unit) temperature	°C
CI2	Second coil value – only dual coil units	°C
CO2	Second coil value – only dual coil units	°C
E(n)	System error where n = an integer	

**Table 4-1, Display Mnemonics and Their Meaning**

## 4.2 SCROLL PUSH BUTTON

---

This button will change what reading is displayed on the screen. Each time you push the button you will advance the display.

## 4.3 PUSH BUTTONS

---

### 4.3.1 COOL Push Button(s)/Indicator(s)

By pressing this button, the unit will go into “COOL”. The button will need to be depressed for a period of about 3 seconds before the unit will go into the “COOL” mode. Referring to Figure 4-1 above. When the unit is in the “COOL” mode the corresponding push button is illuminated.

#### 4.3.1.1 DEFROST Push Button(s)/Indicator(s)

By pressing this button, the unit will go into “DEFROST”. The button will need to be depressed for a period of about 3 seconds before the unit will go into the “DEFROST” mode. Referring to Figure 4-1 above. When the unit is in the “DEFROST” mode the corresponding push button is illuminated. When the unit is “remote” mode, and the unit is in “DEFROST” the push button is illuminated.

#### 4.3.1.2 STANDBY Push Button(s)/Indicator(s)

When power is applied the “Coil#1” STANDBY indicator lamp will be illuminated. Pressing this will start the unit and the unit will then go into the “PRE\_COOL” mode. During the PRE\_COOL time the button will not be illuminated. When the unit has cooled down and the CT is acceptable, the button will re-illuminate (i.e. come back on).



**NOTE:** When in “remote” mode all operate buttons except the “SCROLL” button are disabled

#### 4.3.2 STOP/RESET Push Button.

Pulling on this button will turn the power on to the machine if the Main Switch on the side is in the on position. The display touchscreen will light up. Pushing this will turn off the unit. The unit will automatically reset itself after the STOP/RESET button has been depressed and pulled out to be released. A manual start or renewed remote start signal is required for restart.

### 4.4 OPERATION

---

#### 4.4.1 Turn on the main ISO isolator

Turn on the main ISO isolator located to the right-hand side of the unit. Refer to Figure 3-3

#### 4.4.2 Turning the Unit On

Pull the black STOP/RESET button. LCD should power up.

Depressing the STANDBY button will start the system. In the case of a Dual Circuit system both STANDBY buttons will illuminate. The system will start, and the display will read “Pre-cool”.

When the system is in the pre-cool mode all other modes of operation are disabled, until predefined conditions are met none of the control buttons will illuminate in this state. At the end of the pre-cool phase the STANDBY button will illuminate to indicate the system is able to start cooling. At all times, the SCROLL button remains illuminated

### 4.4.3 Standby

Standby is the normal “resting state” both cool or defrost may be selected when the standby light is illuminated, however defrost will terminate instantly if the CO value is higher than the defrost termination value.

### 4.4.4 Cool

Pressing the cool button activates the cool solenoid valve, allowing refrigerant to flow around the cryo-coil. When the system is in “cool” the button will remain illuminated.

### 4.4.5 Defrost

At any time defrost can be initiated by pressing the defrost button. Following the initiation of defrost the cool solenoid valve is closed and the defrost valve is opened an audible click will be heard. When the system is in “defrost mode” the button will remain illuminated.

While defrosting hot gas passes directly from the compressor into the cryo-coil causing very rapid heating. The system monitors the returning gas temperature in determining if the cryo-coil has been defrosted. If defrost terminates prematurely check the discharge and water temperatures first.

When defrost ends the system automatically enters standby this is indicated both on the display and by the standby button illuminating.

### 4.4.6 Defrost Recovery Period

After defrosting it is possible to enter cool immediately however, better results (faster cycle times and lower temperatures) are achieved if a short period (more than 4 minutes) in standby is allowed for the system to recover. The recovery period is in proportion to the defrost termination temperature and the duration of the defrost cycle. A longer defrost period and the higher termination temperature both increase the recovery period. A good rule of thumb is if the discharge pressure is less than 250 psi then it is fully recovered.

## 4.5 NORMAL OPERATING RANGES

---

The table below provides the range of acceptable parameters during normal operation. Should observations reveal running outside the ranges as given below, then you should contact Telemark or their representative at the earliest opportunity.

Parameter	Description	Acceptable (normal) range
SP start up *	Suction Pressure	20 to 120 psi
DP start up *	Discharge pressure	100 to 470 psi
SP unit running		7 to 60 psi
BP (system off)	System balance pressure	170 to 275 psi
CT	Coldest temperature	-100 to -160C
LT	Liquid Line temperature	10 to 30C
CI	Coil in temp	+90C to -140C
CO	Coil out temp	+20C to -140C

**Table 4-2, Normal Operating Ranges**



**IMPORTANT** – Turning the compressor on/off/on by cycling the power or using the remote function to turn on/off/on can cause damage to the compressor. False alarms/failures may also occur because of cycling the power to the compressor too quickly as gas pressures inside the unit will not have sufficient time to equalize.

You **must** allow 15-30 seconds before cycling the power to the compressor.

## 5 TROUBLE SHOOTING GUIDE

---

### 5.1 TROUBLE SHOOTING

---

Cryochiller water vapor vacuum pumps are made up of 4 essential sub systems.

1. Refrigeration system
2. Power electrical / Water supply
3. Low voltage electrical and interface
4. Control electronics

### 5.2 REFRIGERATION LEAKS

---

These are the number one causes of poor system performance and failure. Almost all leaks in the field are attributable to poor installation practices.

Checking the system balance pressure. If a leak is suspected the system should be shut down for a period of approximately 48 hours (or until the value of the CT is greater than 10°C.) The value of DP (otherwise known as "Balance Pressure") should be taken and compared with the value following installation.

On power up the suction pressure, discharge pressure or liquid line temperature may be outside of acceptable values, correct these first before attempting to start the system.

### 5.3 ALARM CODES/MESSAGES

---

In an alarm Condition the unit will normally shut down and display an alarm message or error code as displayed shown below. Refer to table below for error code listing and the trouble shooting guide table for possible remedies.



Note: Observe and note all alarm messages before resetting unit. Repeated alarm messages can be an indication of imminent system failure or failure of the water supply. The system will shut down if control parameters are breached and an error message will be displayed: If a system parameter is breached a manual reset is required.

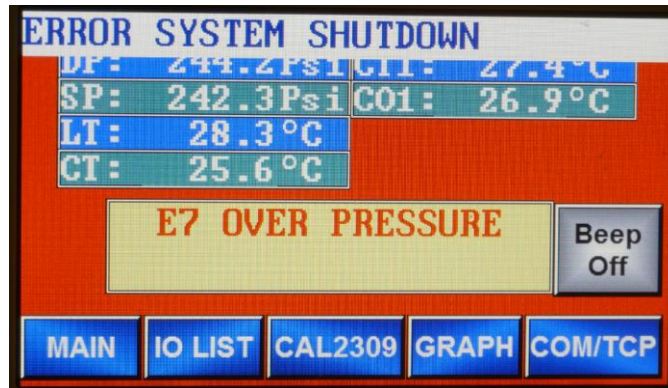

Figure 5-1, "OVER PRESSURE" Alarm Message

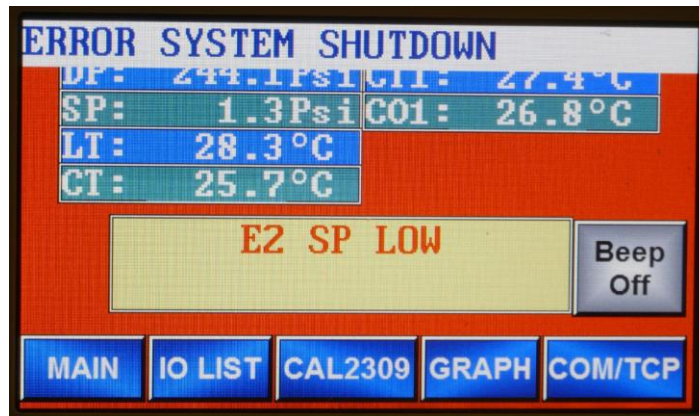

Figure 5-2, "E2" With Fault Shown as "SP LOW"

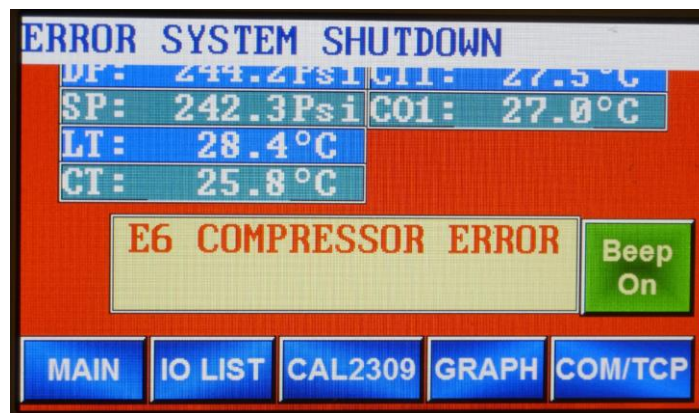

Figure 5-3, "E6" With Fault Shown as "E6 COMPRESSOR ERROR"

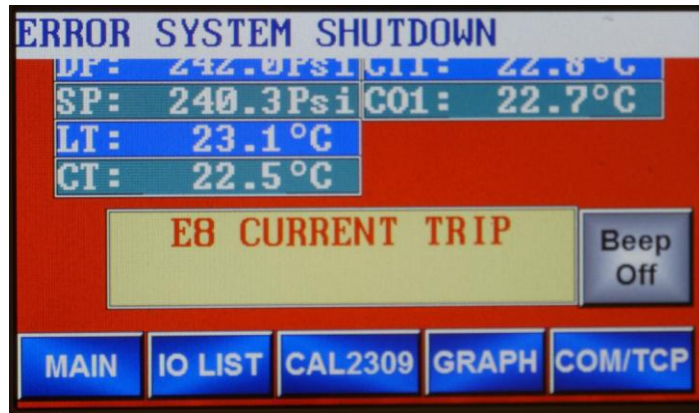

Figure 5-4, "E8" With Fault Shown as "E8 CURRENT TRIP"

Error Code	Display Message	Means
E6	Compressor Error	System Shutdown
E8	Compressor Error Over Current.	Current Trip on compressor contactor thermal overload
E2	SP Low	Suction pressure low – System Shutdown
E3	LL High	Liquid Line temperature high (greater than 40 oC)
E4	DP Fail	Discharge Pressure – System Shutdown
E5	SP Fail	Suction Pressure Fail – System Shutdown
E7	Over Pressure	Reset Pressure Switch
	Phase Detection	Compressor Running Backwards

Table 5-1, Listing of Alarm Messages and Error Codes

## 5.4 SAFETY SYSTEMS

Telemark Cryochillers are protected with both hardware and software systems that will put the unit into alarm condition.

### 5.4.1 Hardware Safety systems

**Compressor Thermal Overload** – this is located in the main electronics tray, and should the compressor draw too much current due to a fault winding, phase missing or too high pressure then this will trip, and an error message will be displayed. To reset this, the side panel must be removed to gain access, and the overload needs to be manually reset.

**Over Pressure Switch** – located inside the machine this is a pressure switch to protect the unit from being over pressurized or running in an over pressure condition. To Rectify and over pressure condition it will need to be manually reset using the green re-set button located on the top of the pressure switch.

**Thermal Snap Switch** – on units fitted without Core Sense module, this is located about 6” away from the compressor on the discharge line. If the discharge temperature exceeds the limit of the switch, then the unit will shut down and the unit will display “COMPRESSOR ERROR”. On the top of the switch there is a manual reset button that needs to be reset by pushing it in.



**Note:** In all above cases the trip(s) **MUST** be manually reset, and the power cycled on the unit before the unit will re-start.



**Note:** Continuous tripping of the Thermal Snap Switch indicates that there is a more serious problem and technical advice should be sought from Telemark as soon as possible.

## 5.5 TROUBLE SHOOTING GUIDE

---

The following table provide a trouble shooting guide.

Symptom	Possible Cause	Corrective Action
Screen does not turn on	No system power	Check mains input
	Missing phase	Check mains input
	Stop/Reset not reset	Reset by pushing and pulling the Start stop button.
	.	
System runs and then stops	Check screen for system status	Most common cause of this is either the value for discharge pressure DP too high or the suction pressure too low. Check over pressure trip and review system balance pressure.
	There has been a momentary power out. check rest of plant.	Reset Push Stop/Reset button and pull to reset
Phase error	Compressor noisy – There is a phase problem.	Screen should give message, Compressor Error. Swap 2 of the phases reset system and restart.
E3 LT High	Check the LT temperature does not exceed the pre-set value (40oc) especially during initial cool down or when the system is under full load. At these points the heat dissipated to the water is at its maximum E3 LT High displayed	Most likely cause is cooling water inadequate flow, or the cooling capacity of your chiller is too low. Check water flow in and water flow out correct orientation.
Over Pressure  Display Message “OVER PRESSURE”	System mechanical over protection triggered	During the initial cool down it is possible the balance pressure was too high, the cooling water flow was too low / reversed or there was a problem with the systems off-load valve. Reset system and restart if fault persists allow system to warm up until CT is at least +10 C and check system balance pressure.

Symptom	Possible Cause	Corrective Action
<p>System does not cool CT fails to get colder than -140 to -150oc after 45 minutes in standby</p> <p>Error Code "E3" Error Code "E2"</p>	<p>Water temperature too high or too low</p>	<p>Correct water temperature and flow rate reset system</p>
	<p>System has a leak</p>	<p>System should be shut down for a period of approximately 48 hours (or until the value of CT is greater than 10°C. The values of DP and SP should be taken and compared with the values following installation. Locate and repair leak pay attention to all flare and refrigeration line joints before topping system up to recommended pressures.</p>
	<p>If SP is above 45 psi the start valve may have become stuck open. Typically, CT will also not be lower than -100oc</p>	<p>With valve cover removed and the system powered, check the start valve solenoid becomes magnetized (use screwdriver). If solenoid magnetized switch unit off and restart after 30 minutes. If the coil is not magnetized switch unit off. Remove valve solenoid and heat valve gently to 100°C with hot air gun. Cryochiller systems have a patented refrigeration system, which prevents valve problems under normal operation. Almost all solenoid valve problems are traced to poor installation introducing moisture into the vacuum system.</p> <p>If this does not correct fault stop unit allow to warm up for 48 hours and restart.☒</p>
<p>Unit does not cool when in "COOL" mode. CI and CO temperatures do not drop</p>	<p>Cool valve hand valve is closed, or common return (suction hand valve) is closed</p>	<p>Switch off allow valves to return to ambient temperature before attempting to open. Operating valves while cold can cause damage. Occasionally common return (suction hand valve) may become stuck down in this case the cryo-coil should be isolated and the procedure for installation should be repeated</p>

	Cool solenoid valve not functioning	With valve cover removed and the system in cool, check the cool valve solenoid becomes magnetized (use screwdriver). If solenoid is operational run system in standby remove valve solenoid and heat valve gently to 100°C with hot air gun. Replace solenoid and attempt cooling – Cryochiller systems have a patented refrigeration system, which prevents valve problems under normal operation. Almost all solenoid valve problems are traced to poor installation.
<b>Symptom</b>	<b>Possible Cause</b>	<b>Corrective Action</b>
System has poor cooling with large temperature differential between CI and CO	Too much heat is being applied to the cryo-coil	Remove Internal heat source
	Possible refrigeration leak	Check values of SP DP CT LT While in cool, and standby and compare with previous logged values
	Poor system design	Consult Telemark for free application advice. Aim for a cryo-coil, which has low mass, high surface area, low volume and a small resistance to flow.
	Cryo-coil or refrigeration lines have become damaged	It is common for the refrigeration lines to be twisted or damaged. The entire refrigeration circuit should be free from restrictions
	Hand valves not fully open	Check defrost and suction line hand valves have been opened

System has poor cooling with small temperature differential between CI and CO	Process problem <sup>2</sup>	<p>The UNIT is designed to have a maximum stabilized temperature differential between CI and CO values of 20oc. It is possible for absolute temperatures and in chamber conditions to vary for the following reasons</p> <p>Ambient humidity -</p> <p>Moisture levels in substrate or poor chamber cleaning increasing levels of out-gassing</p> <p>Poor process control especially if substrate heaters are part of your process.</p> <p>If the cross over pressure is too high when the UNIT is switched to cool there is a significantly increased heat load – aim for 5 x 10-3 mbar – Consult tables in section 4</p>
System is slow to cool		It typically takes 15 – 30 seconds for an appreciable drop in the temperature at CI. This may be longer if remote sensors are being used
	Damaged refrigeration lines especially the cryo-coil and return refrigerant line	Check line for blockages and twists.
	System is placed in cool too soon after termination of defrost <sup>2</sup>	The UNIT requires some time to liquefy refrigerant to feed the cryo-coil fully when in cool. Try optimizing your process by lengthening the standby period following a defrost. Typically, 1 minute of extra standby will speed cooling to the base temperature by about 2 mins
	Cryo-coil has too big a thermal mass	Redesign cryo-coil using thinner gauge material

**Table 5-2, Troubleshooting Guide**

## 5.6 THE USE OF “TOP-OFF” GAS CHARGES

The user should periodically shut the system down and check the balance pressure of the unit. The unit should be shut down for a period of 24 hours to allow the unit to warm up. Ideally the CT (coldest temperature) should be between 15°C to 20°C. The balance pressure should be in the region of 180Psi to 240 PSI (12.4 bar to 16.5 bar) depending upon the unit model. See specifications in Section one of this manual for balance pressures.

The main cause for loss of pressure is due to coupling leaks.

If the balance pressure is too low, it can adversely affect the performance of the Cryochiller (mainly cool and defrost times) and below the minimum pressure care should be taken in deciding whether to add a top-off gas charge or to completely recharge the unit. On this point, it is VERY important to be aware of the history of the unit, as the unit may have been topped off previously.



**Note:** The unit can only be topped off a finite number of times and is also dependent upon the balance pressure at time of topping off the unit. As a rule of thumb if the BP drops to about 170—180 PSI you can normally carry out two top-off procedures. Below 170 PSI Telemark recommends that the unit be recharged to prevent damage to the Cryochiller. After the unit has been top-off more than twice, Telemark recommends that the unit is fully re-charged. Re-charging the unit should only be carried out by trained personnel.

Top-off charges are available from Telemark and some of our world-wide representatives. Part numbers as below

75-1000-00 Kyoto/CE Mark “Green” top-off charge

## 5.7 EMERSON (COPELAND™) COMPRESSOR

---

Some units are fitted with an Emerson Compressor. The following section is for these Models 3600 units only and should not be used with units that are fitted with Bitzer compressors.

The compressor is located at the base of the unit, access can be gained to view the compressor diagnostics by opening the front door or removing the front panel.

Front Cover of Emerson (Copeland®) compressor Diagnostics Panel

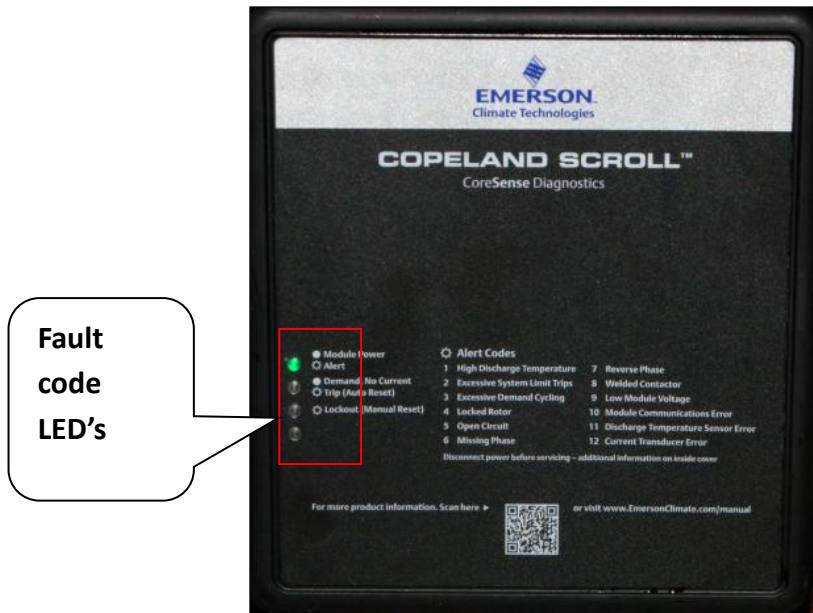

Fault code LED's

Figure 5-5, Emerson Compressor Front Panel Fault Code LED's

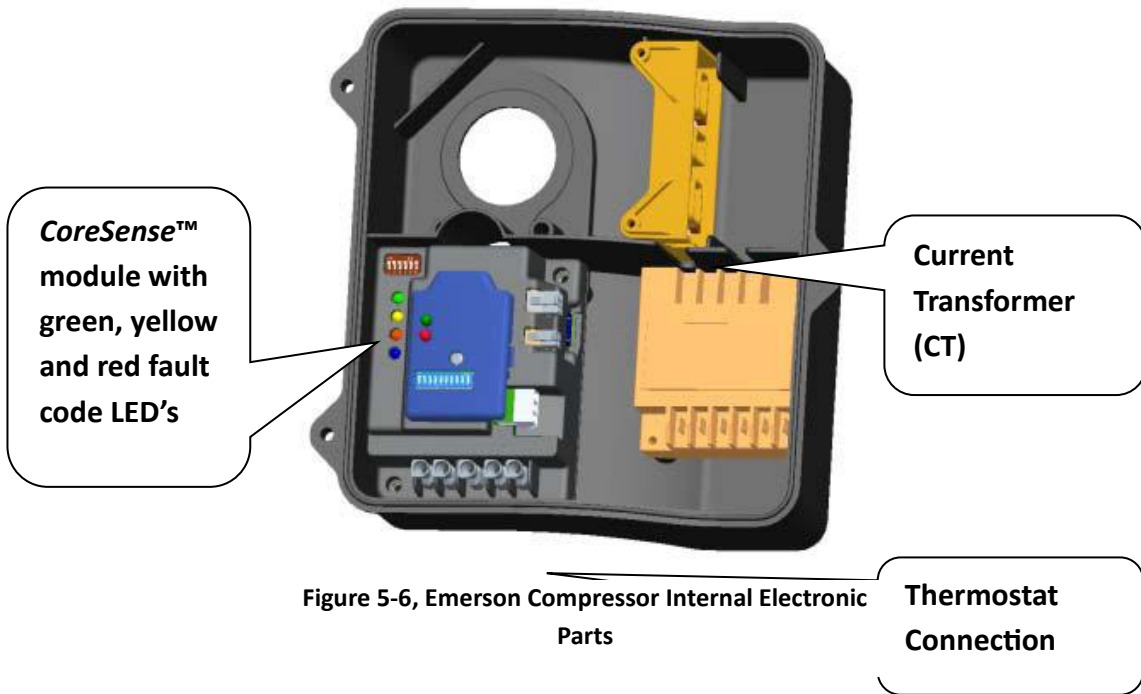

CoreSense™ module with green, yellow and red fault code LED's

Current Transformer (CT)

Thermostat Connection

Figure 5-6, Emerson Compressor Internal Electronic Parts

### 5.7.1 Compressor Diagnostics

#### WARNING



- Failure to follow these warnings could result in serious personal injury.
- Only qualified and authorized HVAC or refrigeration personnel are permitted to carry out repairs and or install the compressor.
- Use appropriate lifting devices to move compressors
- Personal safety equipment must be used.

#### BURN HAZARD



- Failure to follow these warnings could result in serious personal injury.
- Do not touch the compressor until it has cooled down.

#### ELECTRIC SHOCK HAZARD



- Failure to follow these warnings could result in serious personal injury.
- Disconnect power before servicing compressor.
- Compressor must be grounded.
- Electrical connections **MUST** be carried out by qualified electrical personnel.
- Refer to original OEM electrical schematics.

**PRESSURISED SYSTEM HAZARD**



- Failure to follow these warnings could result in serious personal injury.
- System contains refrigerant and oil under pressure.
- Use only approved refrigerants and refrigeration oils.
- Personal safety equipment must be used.

The table below describes the Emerson (Copeland®) fault descriptions via the CoreSense™ module that monitors the operation of the compressor.

**Green LED:**

FLASHING: Alert codes that do not have a protective shutdown.

**Yellow LED:**

FLASHING: Alerts of abnormal compressor operating conditions.

SOLID: demand is present but no current detected. All protective shutdown will auto reset.

**Red LED:**

FLASHING: Indicates the module (compressor) is locked out on any alert code. A full system shutdown is required to rest the alarm condition after the fault has been rectified.



**LOCKED OUT ON:** codes will require the Cryochiller to be powered down to reset the alarm condition after the fault has been investigated and rectified.



The *CoreSense*™ module will continue to display the code until the fault condition has been rectified and or manual power reset (unit Powered off) has been carried out. More than one LED can be illuminated depending upon the fault.



The *CoreSense*<sup>™</sup> LED's will flash at about one every second with a three second pause in between each flashing cycle. (i.e. x number of flashes followed by a pause).

Status LED	Status LED Description	Status LED Troubleshooting Information
Green Alert LED Solid	Module supply voltage present. Compressor running OK	Supply voltage present. Compressor Running OK
Green Alert LED 3 Flashes	Short Cycling. Compressor power on/off too many times	Check pressure or temperature control. Possible loss of refrigerant. Condenser fail.
Green Alert LED 5 Flashes	Open Circuit Demand signal is present but no compressor current for four (4) hours	Compressor Thermal Overload trip. Compressor Contactor Failed. Open Circuit in compressor supply wiring. Compressor Windings Damaged.
Green Alert LED 8 Flashes	Welded Contactor. No demand signal, but current has been detected in one or all of the 3 phases. This is displayed for 24 hours after last detection	Contactor welded closed. Thermostat demand signal not connected to module. Verify the wiring from the thermostat to module.
Green Alert LED 11 Flashes	Discharge Temperature Sensor Error. Short or open circuit detected.	Check discharge Temperature sensor wiring and mounting. Check for open or short circuit. (Resistance 86 kΩ @ 77°F (25°C).
Green Alert LED 12 Flashes	Current Transducer (CT) error	Check CT module plugged into module. Check for short circuit on CT module.
Yellow Alert LED Solid	Trip Demand Present but no current detected.	Compressor Thermal Overload tripped. High Pressure Trip switch Tripped. Reset. Contactor failure.
Yellow Alert LED 1 Flash	High Discharge Line Temperature Trip. Discharge line greater than 250°F (121°C)	Possible loss of refrigeration. Blocked condenser. Discharge line blocked or Rotolok™ valve closed.
Yellow Alert LED 2 Flashes	System Trip Four (4) consecutive Compressor tripped after run time of 1 to 15 minutes.	Excessive suction pressure of discharge pressure. Improper wiring (check phase rotation wiring). Unit over charged. Check balance pressure ≤ 275 PSI.
Yellow Alert LED 4 Flashes	Locked Rotor Compressor is drawing current but not rotating.	Low line voltage. Phase missing. (Check phases present) Excessive liquid refrigeration in compressor.

Yellow Alert LED 6 Flashes	Missing Phase. Demand signal is present but current is missing from one of the phases.	Check Wiring. Check voltage on each of the phases. Failed Contactor.
Yellow Alert LED 9 Flashes	Low voltage detected. Control below or has dropped below 85 volts	Low line voltage. Check wiring connections.
<b>Status LED</b>	<b>Status LED Description</b>	<b>Status LED Troubleshooting Information</b>
Red Alert LED 1 Flash	LOCKED OUT ON: High discharge line temperature trip	Possible loss of refrigerant charge. Blocked Condenser. Discharge line blocked or Rotolok™ valve closed.
Red Alert LED 4 Flashes	LOCKED OUT ON: 4 consecutive locked rotors detected. Compressor is drawing current without rotating.	Low line voltage. Check 3 phase voltage supply. Excessive liquid refrigerant in compressor. Compressors bearing are seized. Check running current.
Red Alert LED 6 Flashes	LOCKED OUT ON: 10 missing phase detections Demand current is present but current is missing a phase	Check phase rotation. Check phase wiring. Check thermal overload. Check contactor and wiring.
Red Alert LED 7 Flashes	LOCKED OUT ON: 1 reverse phase detected. Demand signal is present, but phase current sequence is correct	Check phase wiring order. Check voltage present an all phases. Compressor current draw too low.

**Table 5-3, Emerson LEDs**

## 6 DECOMMISSIONING

---

Should it be necessary to remove the unit from the vacuum system the following procedure must be followed.

### WARNING

The refrigeration system contains a mixed blend of refrigerants and polio-ester oil. These do not present acute health risks it is essential that the following basic precautions are followed:

- Always wear eye protection.
- Always wear surgical type gloves.
- Only fully trained personnel certified in the handling of refrigerants should attempt to decommission any system containing refrigerants.



**WARNING**

System contains specific hazards, which present a significant danger to personal safety:



- High pressure refrigerant gases are a significant frostbite hazard.
- Refrigerant gases will cause asphyxiation followed by death in confined areas.
- Refrigerant gases, which if exposed to high temperatures decompose to form very toxic by-products – never smoke in the vicinity of a TVP or any other similar system including the gas cylinders.

*There are strict regulations concerning the recovery and discharge of all refrigerants into the environment. Penalties can be severe if decommissioning is carried out by untrained persons or if release to the environment occurs.*

- Run the system in standby mode until the unit reaches a stable value for SP.
- Then close common return hand valves. This means ensures that 90% of the refrigerant which is resident in the cryo-coil and lines is recovered back to the TVP.
- Residual gas in the lines must then be reclaimed via the access valve to an empty reclaim cylinder using an oil free refrigerant reclaim unit. Care should be taken to not contaminate the reclaimed gas with air.

**Note:** The reclaimed gas may then be used when the system is reinstalled during the balancing procedure previously described.

## 7 DESIGN OF CRYO-COILS

---

The design and placement of a cryo-coil is a specialized task, which must be carried out by a skilled vacuum practitioner. Free technical help is available directly from Telemark. Telemark also manufactures cryo-coils to order to suit your installation.



It is good practice for cryo-coils with attached feed-through to be installed from inside the chamber so that there are no connections within your vacuum system, verify that moving parts within your vacuum chamber do not interfere with the cryo-coil. Telemark supplies a range of high-quality vacuum feedthroughs, which complement its range of refrigeration lines



The cryo-coil should be more than 1 diameter away from the chamber wall or any other object including other parts of the cryo-coil. It is bad practice to mount the cryo-coil directly onto a metal plate. The ideal cryo-coil should have a large surface area but also be of low mass. The cryo-coil should be capable of accepting a working pressure of 275 psi. If chamber radiant heating is being used aluminum foil placed between the cryo-coil and the heat source is a very effective heat shield, however it may reduce vapor trapping speed. Radiated

heat from any source in a vacuum chamber will have a detrimental effect on the cryochiller.

The design and placement of cryo-coils assumes a basic understanding of the principles of vacuum pumping, many good texts on the subject are available from Leybold™, Edwards™ and other general vacuum equipment suppliers.

It is important to appreciate that a unit will only pump water efficiently in conditions of molecular flow i.e. In vacuums of less than  $1 \times 10^{-3}$  mbar. Where the pressure exceeds this value before the system is switched to cool there is a risk of over loading and saturating the cryo-surface, which may lead to poor process quality and slower pump downs. The temperature at which the unit may be placed in cool is known as the crossover pressure and is analogous to the same criteria, which is applied to other forms of secondary pump.

A unit's performance is conductance limited i.e. Its maximum pumping speed is directly related to the exposed surface, because of the high efficiency of the unit it is generally possible to use larger cryo-surfaces than traditional systems of equivalent power consumption.

Model	Suggested cryo-surface	Sustainable H2O pumping speed (30% de-rating)
1200	0.797 M <sup>2</sup>	65,000 l/s
1800	0.996 M <sup>2</sup>	100,000 l/s
1800 EXT	0.996 M <sup>2</sup>	100,000 l/s
2400	1.395 M <sup>2</sup>	135,000 l/s
3000	1.59 M <sup>2</sup>	165,000 l/s
3600	1.99M <sup>2</sup>	200,000 l/s
4800	2.52M <sup>2</sup>	270,000 l/s

**Table 7-1, Coil Surfaces and Theoretical Pumping**

See table 7-1 for maximum recommended coil surfaces and theoretical pumping speed for water vapor at -105C coil average temperature.



Note: The above performance figures are for units running with a 60Hz mains frequency.

The value for the sustainable pumping speed represents a 30% reduction to account for factors such as proximity of system components reducing conductance and the accumulation of ice reducing heat transfer. The de-rating is subjective and unique to each installation and process.

Since the pumping action is a function of temperature the cryo-surface must be designed to minimize heat gains from sources of external heat. In a perfect system all the heat load placed on the unit would come from the condensation of water. Internal heat from the mass of the coil also must be removed before the system is capable of pumping therefore a design which uses a thermally conductive material of low mass should be selected.

- The construction of ideal cryogenic surface
- Appropriate surface area for system
- Copper or Stainless-steel construction
- Thin Wall
- Large surface area volume ratio
- Internal volume of not less than 0.4 Liters
- A pressure drop between the inlet and outlet of less than 0.3 bar or equivalent to 40M 12.5mm (1/2") smooth tubing.
- Capable of handling a pressure of 17 bar (250PSIG) over a temperature range of +160°C to -160°C
- Simple to clean – coating processes often create large amounts of powdery deposits which reduce the efficiency of the Cryochiller.

The most common form of cryo-surface is Stainless 304. The simplest (but perhaps most expensive) to work is 12mm (1/2") refrigeration grade copper tubing the only significant limitation or consequence of using a thicker wall tubing would be the thermal mass is usually high, resulting in slowing the rate of cooling significantly.

- a. The surface should be clear of any moving parts within the vacuum system.
- b. No closer than 25mm to any chamber wall and out of direct line of sight with heaters or other forms of heat (magnetrons etc.) – if this is unavoidable then the surface can be effectively shielded by aluminum foil.
- c. In systems where there is a great deal of water evolved such as roll / web coating of paper and other materials or where the film is moisture sensitive process improvements can be made by placing the cryo-surface close to the point of moisture generation e.g. The unwind area of a web coater.
- d. Consideration should be given to where the trapped water goes once the surface has been defrosted, a drain may be required if there is a lot of water.

- e. Do not place refrigerant couplings within the vacuum system.

## 8 CHINESE SAFETY DATA SHEET

---

The Refrigerant Charge Safety Data Sheets can be located on the Flash drive under the heading Safety Data sheets

# 表1 有毒有害物质或元素名称及含量标识格式

## (Chinese Hazardous Substances Concentration Table)

Telemark Cryogenics Water Vapor Cryotraps Models: 1200, 1800, 1800 EXT, 2400, 3000, 3600  
Including "D" Models

Declaration of Hazardous Substance						
Part Name 部件名称	Toxic or hazardous Substances and Elements 有毒或有害物质或元素					
	Lead (Pb) 铅	Mercury (Hg) 汞	Cadmium (Cd) 镉	Hexavalent Chromium (Cr (VI)) 六价铬	Polybrominated biphenyls (PBB) 多溴联苯	Polybrominated diphenyl ethers (PBDE) 多溴二苯醚
Water Vapor Pump All Models 水汽泵	X	X	X	X	X	X
Compressor 压缩机	X	X	X	X	X	X
Accessory 辅助部件	X	X	X	X	X	X

*O: Indicates that this toxic or hazardous substance contained in all of the homogeneous materials for this part is below the limit requirement in SJ/T11363-2006.*

**O:** 表示该有毒有害物质在该部件所有均质材料中的含量均在 SJ/T11363-2006 规定的限量要求以下。

*X: Indicates that this toxic or hazardous substance contained in at least one of the homogeneous materials used for this part may be, or is, above the limit requirement in SJ/T11363-2006. (Enterprises may further provide in this box technical explanation for marking "X" based on their actual conditions.)*

**X:** 表示该有毒有害物质至少在该部件的某一均质材料中的含量超出 SJ/T11363-2006 规定的限量要求。(企业可在此处·根据实际情况对上表中打"x:"的技术原因进行进一步说明。